

vEX IQ
ROBOTICS
COMPETITION
FULL VOLUME

2023 - 2024
Game Manual
Version 2.1

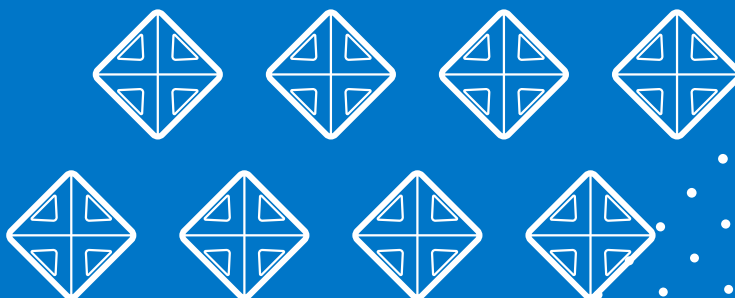

Table of Contents

Section 1

The Game.....	1
General Definitions.....	5
Game-Specific Definitions	9
Scoring.....	14
Safety Rules	19
General Game Rules	19
Specific Game Rules.....	25

Section 2

The Robot	27
Inspection Rules.....	27

Section 3

The Event	34
Tournament Definitions.....	34
Tournament Rules.....	35

Appendix A - Field Overview

Field Overview.....	A1
---------------------	----

Appendix B - Robot Skills

Robot Skills Challenge Definitions	B1
Robot Skills Challenge Rules	B2
Robot Skills at League Events.....	B5

Changelog

Version 2.1 - October 3, 2023

- Updated <G1> to include a link to the Code of Conduct Process
- Updated <SG3> to state that *Blocks* being returned to the *Supply Zone* should not disturb other *Blocks* or contact a *Robot*
- Updated <R15> to clarify intent
- Updated <T17> to clarify multi-division tournament structure

Version 2.0 - August 1, 2023

- Updated <G2> to clarify intent
- Added a blue box to <G11> to give notice to the addition of a third Drive Team member for the 2024-2025 and 2025-2026 VIQRC games
- Updated <SG1> and <R16> to allow pre-charging of pneumatics
- Updated <SG2> to clarify how *Robots* should be measured horizontally
- Added a new figure to <SG2> to illustrate the above change
- Updated <R15> to include the cutting of pneumatic tubing
- Updated <T1e> to clarify that a *Head Referee* may only watch one *Match* at a time
- Minor typo / formatting fixes

Version 1.0 - June 27, 2023

- Added a new bullet to <T11> to clarify that the Field Reset Pins are optional
- Added <R16> to provide regulations on VEX IQ Pneumatics
- Minor typo fixes

Version 0.2 - June 13, 2023

- Updated rule <G5> to correct metric conversions
- Updated typo in rule <SG1> to be *Goals I and II*
- Updated Figure 18 to provide further clarity to <SG1>
- Updated rule <SG3> to include <G10> interactions
- Updated rule <R4a> to state that *Robots* may only start a *Match* contacting the Floor and Field Perimeter
- Updated rule <R6> to include VEX CTE

Version 0.1 - May 2, 2023

- Initial Release

Quick Reference Guide

Scoring Rules (Pages 14-18)

<SC1>	All Scoring statuses are evaluated after the <i>Match</i> ends
<SC2>	All Scoring statuses are evaluated visually by a <i>Head Referee</i>
<SC3>	<i>Scored Block</i> criteria
<SC4>	<i>Uniform Goal</i> criteria
<SC5>	<i>Height Bonus</i> criteria
<SC6>	<i>Goal Scoring</i> examples
<SC7>	<i>Parked</i> criteria

Safety Rules (Page 19)

<S1>	Stay safe, don't damage the <i>Field</i> .
<S2>	<i>Students</i> must be accompanied by an <i>Adult</i>

General Game Rules (Pages 19-24)

<G1>	Treat everyone with respect
<G2>	VEX IQ Robotics Competition is a student-centered program
<G3>	Use common sense
<G4>	The <i>Robot</i> must represent the skill level of the <i>Team</i>
<G5>	<i>Robots</i> begin the <i>Match</i> in the starting size
<G6>	Keep your <i>Robot</i> together
<G7>	Don't damage the <i>Field</i>
<G8>	<i>Drivers</i> drive your <i>Robot</i> , and stay in the <i>Driver Station</i>
<G9>	Hands out of the <i>Field</i>
<G10>	Handling the <i>Robot</i> mid-match is allowed under certain circumstances
<G11>	A <i>Team's</i> two <i>Drivers</i> switch <i>Controllers</i> midway through the <i>Match</i>

Specific Game Rules (Pages 25-26)

<SG1>	Pre-match setup.
<SG2>	Horizontal expansion is limited during a <i>Match</i> .
<SG3>	Keep <i>Blocks</i> in the <i>Field</i>
<SG4>	<i>Blocks</i> are randomly loaded in the <i>Supply Zone</i>

Robot Rules (Pages 27-33)

<R1>	One <i>Robot</i> per <i>Team</i>
<R2>	<i>Robots</i> must represent the <i>Team's</i> skill level
<R3>	<i>Robots</i> must pass inspection
<R4>	Starting configuration
<R5>	Prohibited items
<R6>	VEX IQ product line
<R7>	Non-VEX IQ components
<R8>	Decorations are allowed
<R9>	Officially registered <i>Team</i> numbers must be displayed on <i>Robot License Plates</i>
<R10>	Let it go after the <i>Match</i> is over
<R11>	Robot Brain
<R12>	Motors
<R13>	Batteries
<R14>	Firmware
<R15>	Modifications of parts
<R16>	Pneumatics

Tournament Rules (Pages 35-40)

<T1>	<i>Head Referees</i> have final authority on all gameplay ruling decisions
<T2>	<i>Head Referees</i> must be qualified
<T3>	The Drive Team is permitted to immediately appeal a <i>Head Referee's</i> ruling
<T4>	<i>Event Partners</i> have final authority regarding all non-gameplay decisions
<T5>	Be at your <i>Match</i> on time
<T6>	<i>Robots</i> at the <i>Field</i> must be ready to play
<T7>	<i>Match</i> Replays are allowed, but rare
<T8>	<i>Disqualifications</i>
<T9>	Timeouts
<T10>	Be prepared for minor <i>Field</i> variance
<T11>	<i>Fields</i> and <i>Field Elements</i> may be repaired at the <i>Event Partner's</i> discretion
<T12>	<i>Teamwork Matches</i>
<T13>	Ending a <i>Match</i> early
<T14>	<i>Practice Matches</i> may be played at some events, but are not required
<T15>	<i>Qualification Matches</i> will occur according to the official match schedule
<T16>	Each <i>Team</i> will be scheduled <i>Qualification Matches</i> as follows
<T17>	<i>Teams</i> are ranked by their average <i>Qualification Match</i> scores
<T18>	<i>Teams</i> playing in <i>Finals Matches</i>
<T19>	<i>Finals Match</i> Schedule

Robot Skills Challenge Rules (Pages B2-B5)

<RSC1>	Standard rules apply in most cases
<RSC2>	Skills Scoring and Ranking at events
<RSC3>	Skills Rankings Globally
<RSC4>	Skills Match Schedule
<RSC5>	Handling <i>Robots</i> during an <i>Autonomous Coding Skills Match</i>
<RSC6>	Starting an <i>Autonomous Coding Skills Match</i>
<RSC7>	<i>Skills Stop Time</i>

Section 1

The Game

Game Description

VEX IQ Robotics Competition Full Volume is played on a 6'x8' rectangular *Field*, set up as illustrated in the figures throughout this game manual.

The primary objective of the game is to place *Blocks* into *Goals*. Points are awarded based on the number, type, and height of *Blocks* in each *Goal*. Points are also available for *Clearing the Supply Zone*, and for *Parking* in the *Supply Zone* at the end of the *Match*.

In the *Teamwork Challenge*, an *Alliance* composed of two (2) *Robots* works together to score as many points as possible in a sixty (60) second *Match*.

Teams may also compete in *Robot Skills Matches*, where one (1) *Robot* tries to score as many points as possible. See Appendix B for more information.

Note: The illustrations in this section of the Game Manual are intended to provide a general visual understanding of the game. Teams should refer to official field specifications, found in Appendix A, for exact field dimensions, a full field bill of materials, and exact details of field construction.

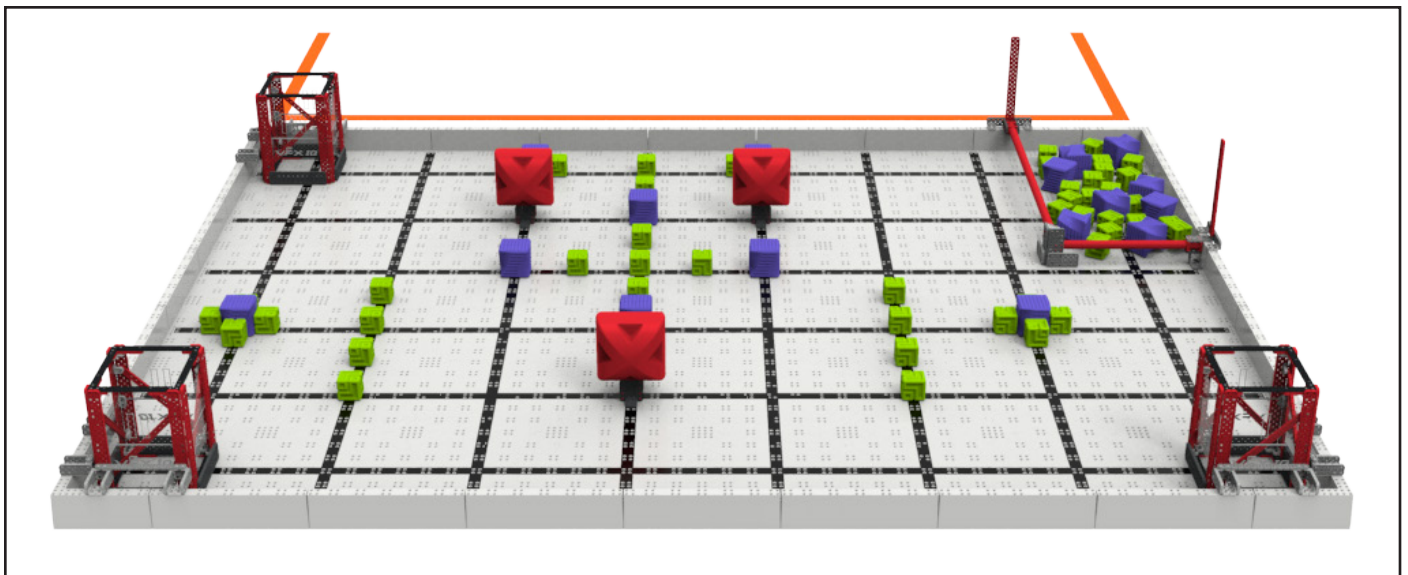

Figure 1: Starting configuration of the *Field* for a VEX IQ Robotics Competition Full Volume Match.

About the Game Manual - A Note from the GDC

This Game Manual and its appendices contain everything there is to know about this season's new game, VIQRC Full Volume. It is intended to be a resource for all *Teams*, *Head Referees*, *Event Partners*, and other members of the VIQRC community.

The rules contained in the following pages can be thought of as "constraints" that define this game, just as engineers begin any design project by defining their constraints. At the beginning of a season, "constraints" are all we have. We don't know what the winning *Robot*, best strategy, or most frequently-violated rule will be any more than you do. Isn't that exciting?

When exploring a new game, please approach this Game Manual with that mentality, and look at rules as "constraints." The Game Manual and its appendices contain the full and complete list of constraints that are available for a competitor to strategize, design, and build their *Robots*.

Obviously, all *Teams* must adhere to these rules, and any stated intents of these rules. However, beyond that, there is no "right" way to play. There are no hidden restrictions, assumptions, or intended interpretations beyond what is written here. So, it is up to you, the competitor, to find the path through these constraints that best suits your *Team's* goals and ambitions.

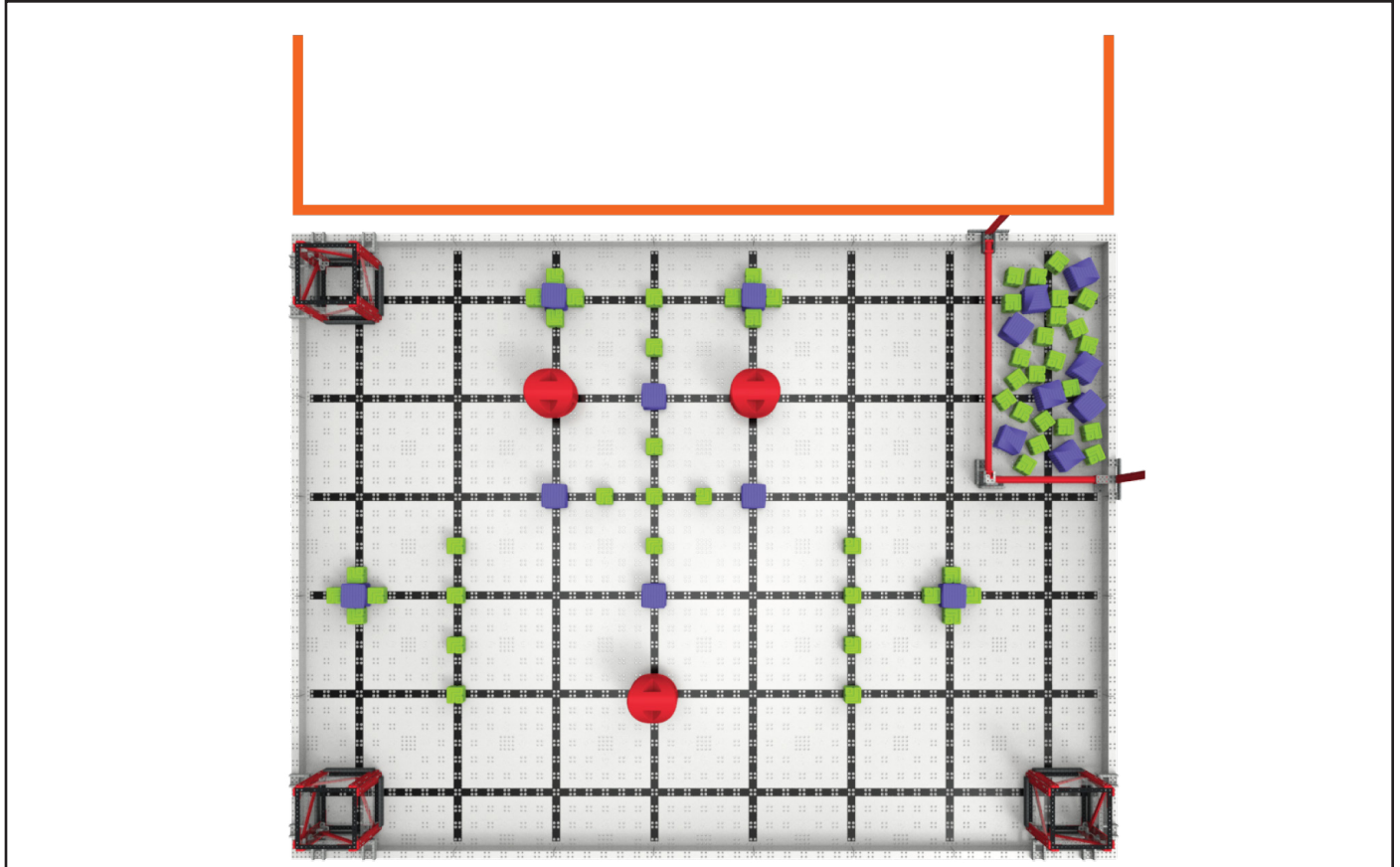

Figure 2: Starting configuration of the Field for a VEX IQ Robotics Competition Full Volume Match.

Updates

This manual will have a series of “major” and “minor” updates over the course of the season. Each version is official and must be used in official VIQRC events until the release of the next version, upon which the previous version becomes void.

Known major release dates are as follows:

May 2, 2023	Version 0.1	Initial game release
May 16, 2023	N/A	Official Q&A system opens
June 13, 2023	Version 0.2	Minor typographical errors or formatting issues found in the initial release. There will be very few rule changes, if any.
June 27, 2023	Version 1.0	May include critical gameplay or rule changes inspired by input from the official Q&A system and the VEX community.
August 1, 2023	Version 2.0	May include gameplay or rule changes inspired by early-season events.
October 3, 2023	Version 2.1	Clarification update only
December 5, 2023	Version 2.2	Clarification update only
January 30, 2024	Version 3.0	May include gameplay or rule changes inspired by mid-season events.
April 2, 2024	Version 4.0	May include critical gameplay or rule clarifications pertaining specifically to the VEX Robotics World Championship

In addition to these known major updates, there may also be unscheduled updates released throughout the season if deemed critical by the GDC. **Any unscheduled updates will always be released on a Tuesday, no later than 5:00 PM CST (11:00 PM GMT).** These updates will be announced via the VEX Forum, automatically pushed to the VIQRC Hub app, and shared via VEX Robotics / REC Foundation social media & email marketing channels.

Game Manual updates are effective immediately upon release; it is every *Team’s* responsibility to be familiar with all rules and updates. There are no “grace periods” if an update prohibits a previously legal part, mechanism, or strategy.

Note: REC Foundation Event Support Managers will contact *Event Partners* involved with multi-week league events that “cross over” an unscheduled update. If a rule change impacts their event (such as a *Robot* which previously passed inspection no longer being legal), these cases will be reviewed individually depending on the context of the event and the rule that has changed. This is the only possible “grace period” exception.

The Q&A System

When first reviewing a new robotics game, it is natural to have questions about situations which may not be immediately clear. Navigating the Game Manual and seeking out answers to these questions is an important part of learning a new game. In many cases, the answer may just be in a different place than you first thought—or, if there is no rule explicitly prohibiting something, then that usually means it is legal!

However, if a *Team* is still unable to find an answer to their question after closely reviewing the relevant rules, then every *Team* has the opportunity to ask for official rules interpretations in the VEX IQ Robotics Competition Question & Answer System. These questions may be posted by a *Team's Adult* representative via the RobotEvents account that is associated with that *Team*.

All responses in this Q&A system should be treated as official rulings from the VEX IQ Robotics Competition *Game Design Committee*, and they represent the correct and official interpretation of the VEX IQ Robotics Competition Rules. The Q&A system is the only source besides the Game Manual for official rulings and clarifications.

The VEX IQ Robotics Competition Question & Answer System can be found at <https://www.robotevents.com/VIQC/2023-2024/QA>.

Before posting on the Q&A system, be sure to review the Q&A Usage Guidelines, which can be found at <https://www.robotevents.com/VIQC/2023-2024/QA/guidelines>.

1. Read and search the manual before posting.
2. Read and search existing Q&As before posting.
3. Quote the applicable rule from the latest version of the manual in your question.
4. Make a separate post for each question.
5. Use specific and appropriate question titles.
6. Questions will (mostly) be answered in the order they were received.
7. This system is the only source for official rules clarifications.

The 2023-24 Q&A is the **ONLY** official source for rulings besides the Game Manual. If there are any conflicts between the Game Manual and other supplemental materials (e.g., Referee Certification courses, the VIQRC Hub app, etc.), the most current version of the Game Manual takes precedence.

Similarly, it can never be assumed that definitions, rules, or other materials from previous seasons apply to the current game. Q&A responses from previous seasons are not considered official rulings for the current game. Any relevant clarifications that are needed should always be re-asked in the current season's Q&A.

General Definitions

Adult – Anyone who is not a *Student*.

Alliance – A pre-assigned grouping of two (2) *Teams* that are paired together during a given *Teamwork Challenge Match*.

Alliance Score – Points scored in a *Teamwork Challenge Match* that are awarded to both *Teams*.

Disablement – A penalty applied to a *Team* for a rule *Violation*. During *Disablement*, a *Team* is no longer allowed to operate their *Robot*, and the *Drivers* will be asked to place their Controller on the ground. A *Disablement* is not the same as a *Disqualification*.

Disqualification – A penalty applied to a *Team* for a rule violation (see <T8> for more details). If a *Team* is Disqualified in a *Match*, the *Head Referee* will notify the *Team* of their *Violation* at the end of the *Match*. At the *Head Referee*'s discretion, repeated violations and/or *Disqualifications* for a single *Team* may lead to its *Disqualification* for the entire event.

Driver – A *Student Team* member who stands in the *Driver Station* and is responsible for operating and controlling that *Team's Robot*. Up to two *Team* members may fulfill this role in a given *Match* (see <G8>).

Driver Station – The region behind the *Field* where the *Drivers* must remain during their *Match* unless legally interacting with their *Robot*.

Field – The entire playing *Field*, being six (6) field tiles wide by eight (8) field tiles long (totaling forty-eight (48) field tiles), including the *Field Perimeter*.

Field Element – The *Field Perimeter*, *Floor*, PVC pipes, and VEX IQ elements which are attached to the *Field*.

Field Perimeter – The outer part of the *Field*, made up of four (4) outside corners and twenty-four (24) straight sections.

Floor – The interior flat part of the playing *Field*, made up of the forty-eight (48) field tiles that are within the *Field Perimeter*.

Game Design Committee (GDC) – The creators of VIQRC Full Volume, and authors of this Game Manual.

License Plate – A physical component on the *Robot* that displays the *Team’s* VEX IQ Robotics Competition number. The *License Plate* must have a length and height of 3.5" x 1.5" (88.9mm x 38.1mm) and must not exceed a width of 0.25" (6.35mm) per <R9>.

Match – A set time period, consisting of *Autonomous Periods* or *Driver Controlled Periods*, during which *Teams* play a defined version of Full Volume to earn points. See Section 3.

- **Autonomous Period** – A time period during which *Robots* operate and react only to sensor inputs and to commands pre-programmed by the *Students* into the *Robot* control system.
- **Driver Controlled Period** – A time period during which *Drivers* operate their *Robot*.

Match Type	Participants	Autonomous Period (m:ss)	Driver Controlled Period (m:ss)
<i>Teamwork Challenge</i>	One <i>Alliance</i> , on one <i>Field</i> , made up of two <i>Teams</i> , each with one <i>Robot</i>	None	1:00
<i>Driving Skills Match</i>	One <i>Team</i> , with one <i>Robot</i>	None	1:00
<i>Autonomous Coding Skills Match</i>	One <i>Team</i> , with one <i>Robot</i>	1:00	None

Robot – A machine that has passed inspection, designed to execute one or more tasks autonomously and/or by remote control from a human operator.

Student – Anyone born after May 1, 2008 (i.e. who will be 15 or younger at VEX Worlds 2024). Eligibility may also be granted based on a disability that has delayed education by at least one year. *Students* are the individuals who design, build, repair, and program the *Robot* with minimal *Adult* assistance.

- **Elementary School Student** - Any *Student* born after May 1, 2011 (i.e. who will be 12 or younger at VEX Worlds 2024). Elementary School *Students* may "play up" and compete as *Middle School Students*.
- **Middle School Student** – Any eligible *Student* that is not an *Elementary School Student*.

Team – Two or more *Students* make up a *Team*. A *Team* is classified as an Elementary School *Team* if all members are *Elementary School Students*. A *Team* is classified as a Middle School *Team* if any member is a *Middle School Student*, or if the *Team* is made up of *Elementary School Students* who declare themselves as "Playing Up" as *Middle School Students* by registering their *Team* as a Middle School *Team*. Once a *Team* has competed in an event as a Middle School *Team*, that *Team* may not change back to

a Elementary School *Team* for the remainder of the season. *Teams* may be associated with schools, community/youth organizations, or a group of neighborhood *Students*.

- **Builder** – The *Student(s)* on the team who assemble(s) the *Robot*. An *Adult* cannot be a *Builder* on a *Team*. *Adults* are permitted to teach the *Builder(s)* associated concepts, but may never work on the *Robot* without the *Builder(s)* present and actively participating.
- **Designer** – The *Student(s)* on the *Team* who design(s) the *Robot* to be built for competition. An *Adult* cannot be a *Designer* on a *Team*. *Adults* are permitted to teach the *Designer(s)* associated concepts, but may never work on the design of the *Robot* without the *Designer(s)* present and actively participating.
- **Programmer** – The *Student(s)* on the *Team* who write(s) the computer code that is downloaded onto the *Robot*. An *Adult* cannot be a *Programmer* on a *Team*. *Adults* are permitted to teach the *Programmer(s)* associated concepts, but may never work on the code that goes on the *Robot* without the *Programmer(s)* present and actively participating.

Violation – The act of breaking a rule in the Game Manual.

- **Minor Violation** – A *Violation* which does not result in a *Disqualification*.
 - Accidental, momentary, or otherwise non-*Score Affecting Violations* are usually *Minor Violations*.
 - *Minor Violations* usually result in a verbal warning from the *Head Referee* during the *Match*, which should serve to inform the *Team* that a rule is being *Violated* before it escalates to a *Major Violation*.
- **Major Violation** – A *Violation* which results in a *Disqualification*.
 - Unless otherwise noted in a rule, all *Score Affecting Violations* are *Major Violations*.
 - If noted in the rule, egregious or intentional *Violations* may also be *Major Violations*.
 - Multiple *Minor Violations* within a *Match* or tournament may escalate to a *Major Violation* at the *Head Referee's* discretion.
- **Score Affecting** – A *Violation* which improves an *Alliance's* score at the end of a *Match*.
 - Multiple *Violations* within a *Match* can cumulatively become *Score Affecting*.
 - When evaluating whether a *Violation* was *Score Affecting*, *Head Referees* will focus primarily on any *Robot* actions that were directly related to the *Violation*.
 - Determining whether a *Violation* was *Score Affecting* can only be done once the *Match* is complete and the scores have been calculated.

Some rules include *Violation Notes* in *red italicized text* to denote special circumstances or provide additional clarifications. If no *Violation Notes* are found in a given rule, then it should be assumed that the above “default” definitions apply.

To determine whether a *Violation* may have been *Score Affecting*, check whether the *Violation* directly contributed to increasing the score of the *Match*. If it did not increase the *Alliance’s* score, then the *Violation* was not *Score Affecting*, and it was very likely a *Minor Violation*.

See the following flowchart for more information.

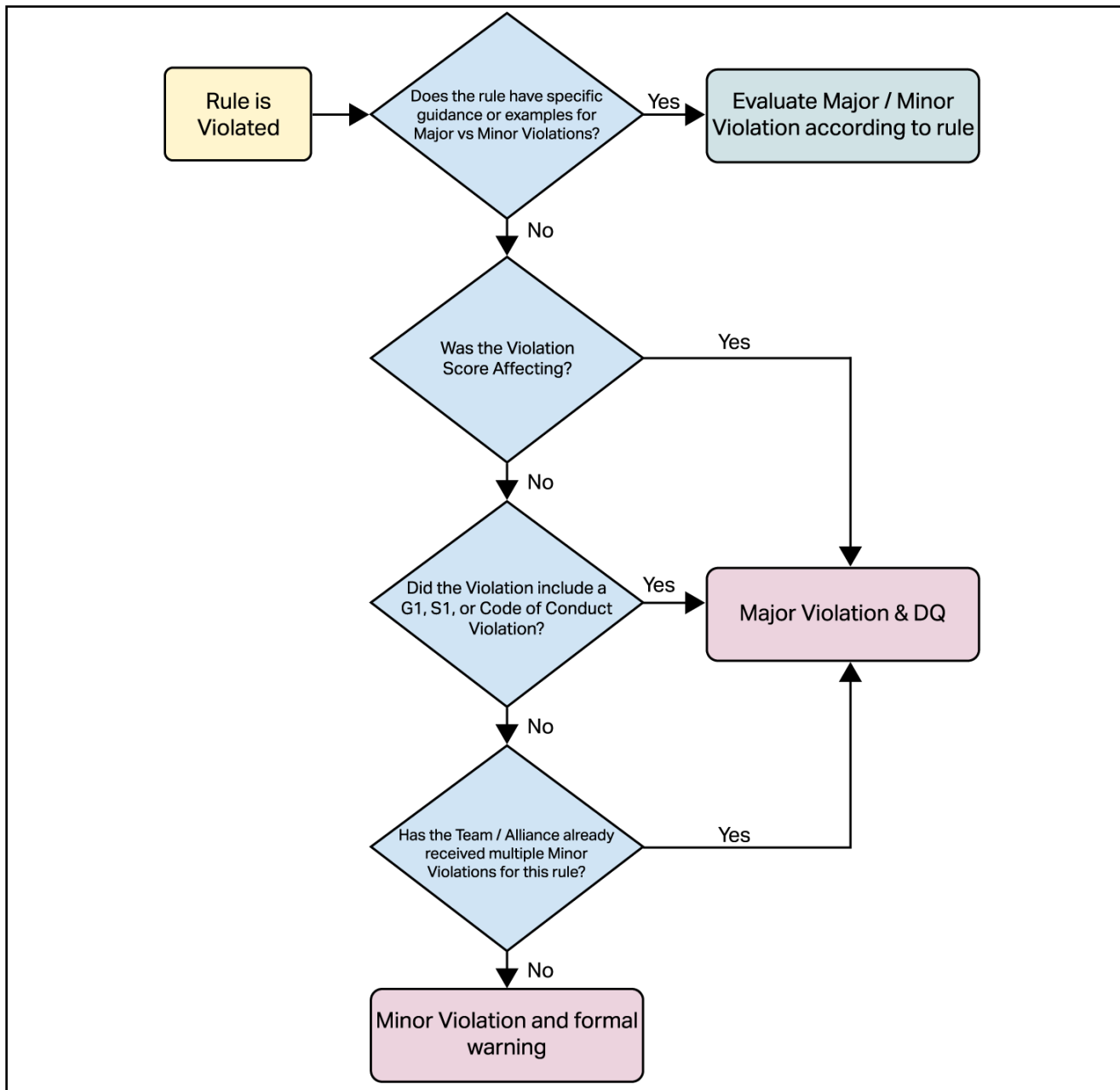

Figure 3: The process for determining Violations in VEX IQRC Full Volume.

Game-Specific Definitions

Block – A green, purple, or red plastic scoring object.

- Each green *Block* consists of six sides, is approximately 2" (51mm) to a side, and weighs approximately 1.1 oz (30g). There are fifty four (54) green *Blocks* on the *Field*.
- Each purple *Block* consists of six sides, is approximately 3" (76mm) to a side, and weighs approximately 1.6oz (45g). There are sixteen (16) purple *Blocks* on the *Field*.
- Each red *Block* is a partially-rounded octagonal shape, has a major diameter of approximately 5.8" (147mm), and weighs approximately 6.3 oz (180g). There are three (3) red *Blocks* on the *Field*.

Cleared – A *Supply Zone* status. The *Supply Zone* is considered *Cleared* if no *Blocks* are fully within the 3D volume of the *Supply Zone* at the end of the *Match*.

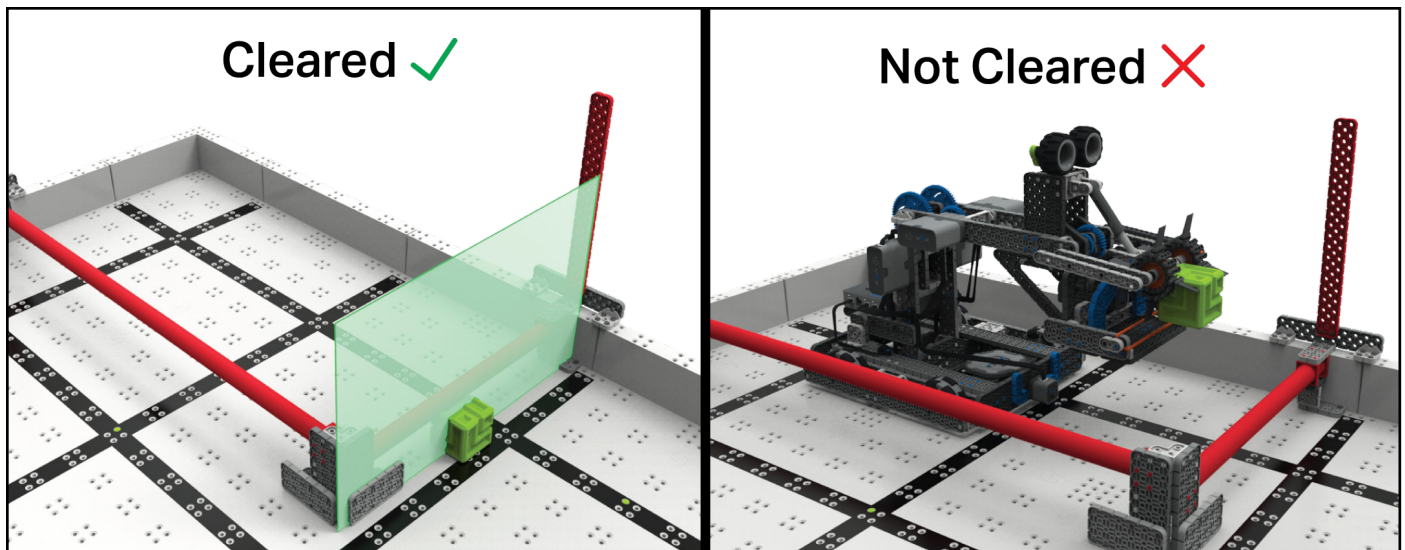
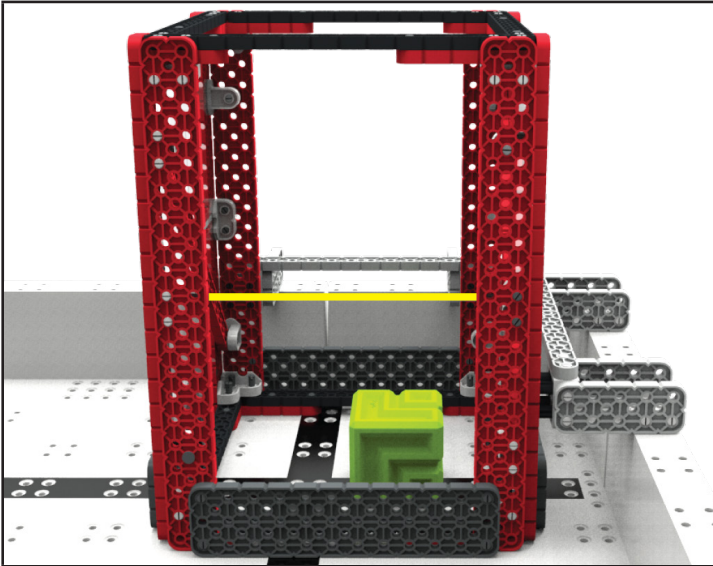
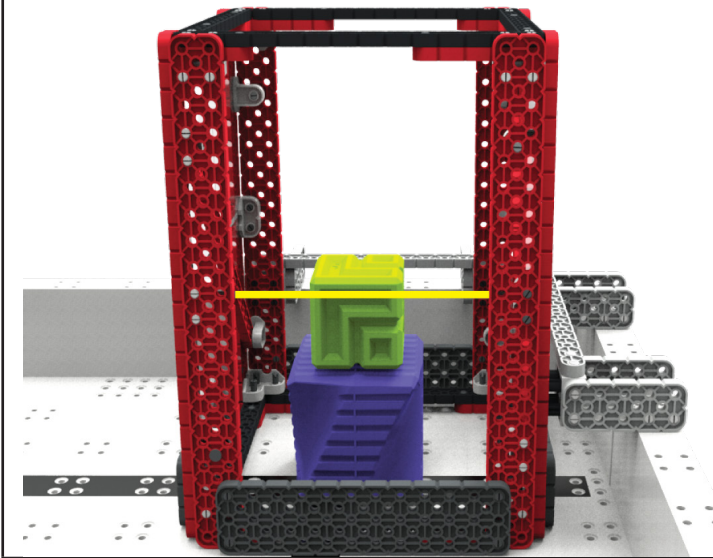

Figure 4: Two example *Supply Zone* states. The example on the left is considered *Cleared* because even though a *Block* is still partially within the *Supply Zone*, it is no longer fully within the *Supply Zone*. The example on the right would not be considered *Cleared*, because the *Block* is still within the boundaries of the *Supply Zone*.

Fill Level – A *Goal* attribute that corresponds to the "highest" *Block(s)* Scored in a given *Goal*. A *Goal* can have one of three possible *Fill Levels* as described below; if a *Goal* meets the requirements for multiple *Fill Levels*, it should be assigned the highest of those *Fill Levels*. *Fill Levels* are used to determine the overall *Height Bonus* at the end of the *Match*.



Fill Level 1: At least one *Block* is contacting the *Floor* within the *Goal*.



Fill Level 2: At least one *Block* is at least partially above the horizontal line printed on the outside of the *Goal*.

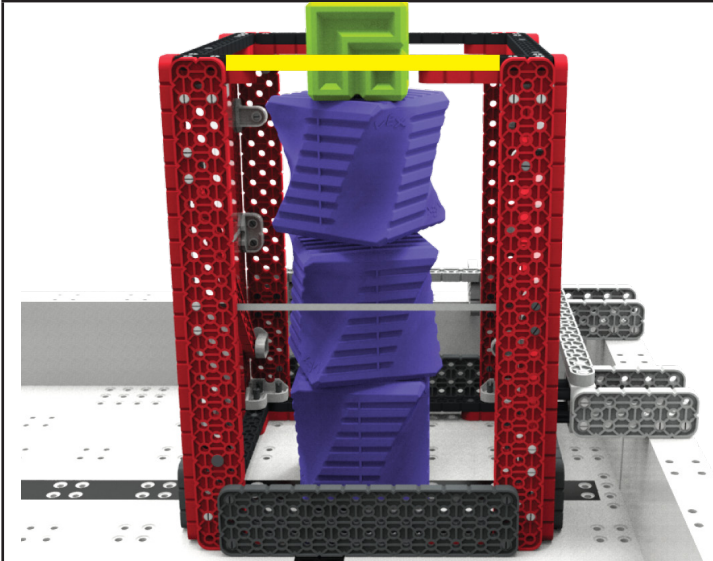

Fill Level 3: At least one *Block* is at least partially above the top of the *Goal*.

Goal – A rectangular-shaped structure built out of VEX IQ parts and clear plastic sheets and connected to a corner of the *Field*. The VEX IQ parts used to connect a *Goal* to the *Field* are not considered part of the *Goal*.

Note: The "I", "II", and "III" labels on each Goal are intended to be common identifiers for Teams and Referees to use instead of referring to them in other ways (e.g. "top-left Goal"). They have no relation to scoring, Fill Levels, Blocks, etc.

Height Bonus – A point bonus awarded at the end of the *Match*. See rule <SC5>.

Parked – A *Robot* status at the end of the *Match*.

- **Partially Parked** – A *Robot* is *Partially Parked* if it is partially within the *Supply Zone*.
- **Fully Parked** – A *Robot* is *Fully Parked* if it is fully within the *Supply Zone*.
- **Double Parked** – An *Alliance* is *Double Parked* if both *Robots* are *Fully Parked*.

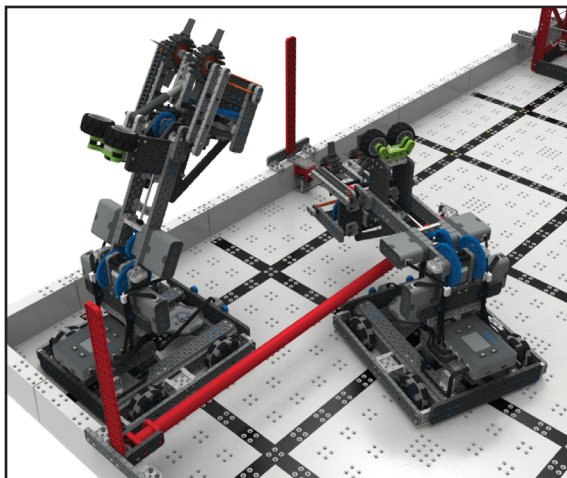

Robot A: Fully Parked ✓
 Robot B: Partially Parked ✓
 Alliance: Not Double Parked ✗

Figure 5: Robot A is completely within the *Supply Zone*, and is *Fully Parked*. Robot B is breaking the plane of the *Supply Zone*, and would be considered as *Partially Parked*. The *Alliance* would not be considered *Double Parked*.

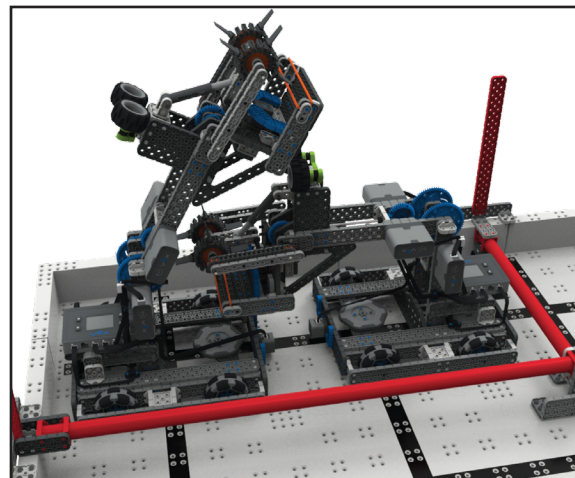

Robot A: Fully Parked ✓
 Robot B: Fully Parked ✓
 Alliance: Double Parked ✓

Figure 6: Both *Robots* are completely within the *Supply Zone*, and *Fully Parked*. The *Alliance* would be considered *Double Parked*.

Scored – A *Block* status. A *Block* is considered to be *Scored* in a *Goal* if it meets the criteria set forth in rule <SC3>.

Removed – A red *Block* status. A red *Block* is considered *Removed* if it is no longer fully supported by a *Starting Peg* at the end of the *Match*.

Starting Peg – One of three (3) *Field Elements* used for setting up red *Blocks* at the beginning of a *Match*.

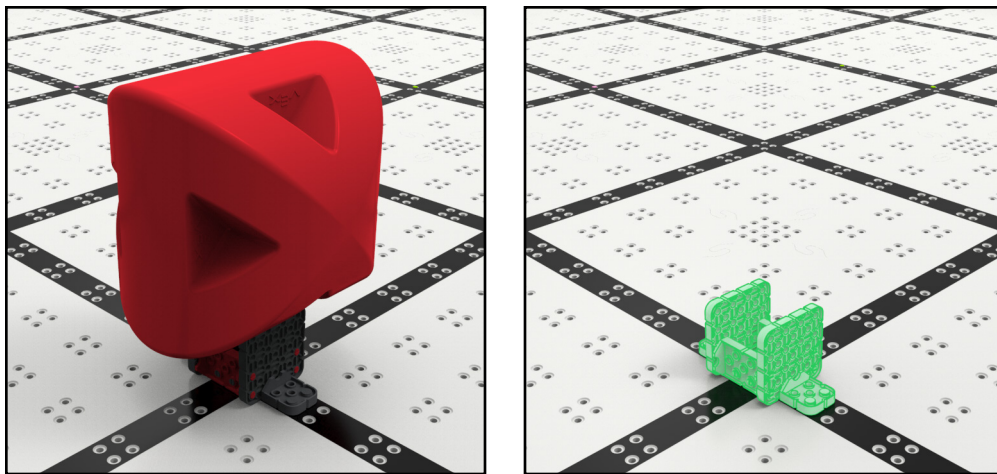

Figure 7: A Starting Peg.

Supply Zone - An infinitely tall three-dimensional volume of the *Field* bordered by the outer edges of the red PVC pipe and the outer edges of the *Field Perimeter* (which coincides with the outer edges of the vertical red VEX IQ beams in 2 of the corners). A predefined number of *Blocks* begin the *Match* within the *Supply Zone* (see rule <SG4>). *Teams* can receive points for *Clearing the Supply Zone*, and for using it to *Park Robots*.

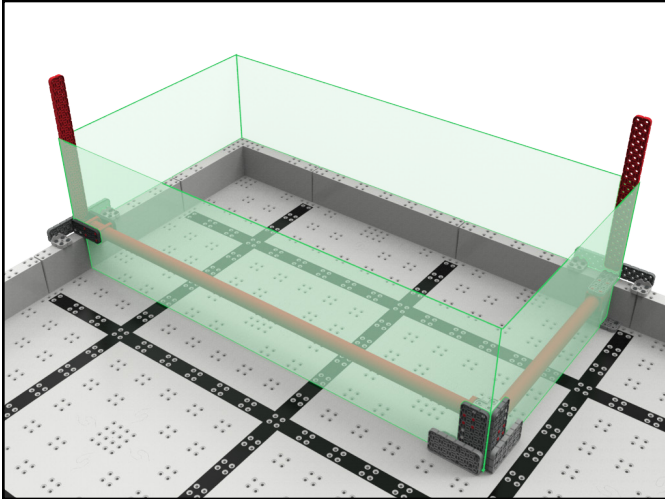

Figure 8: The boundaries of the Supply Zone.

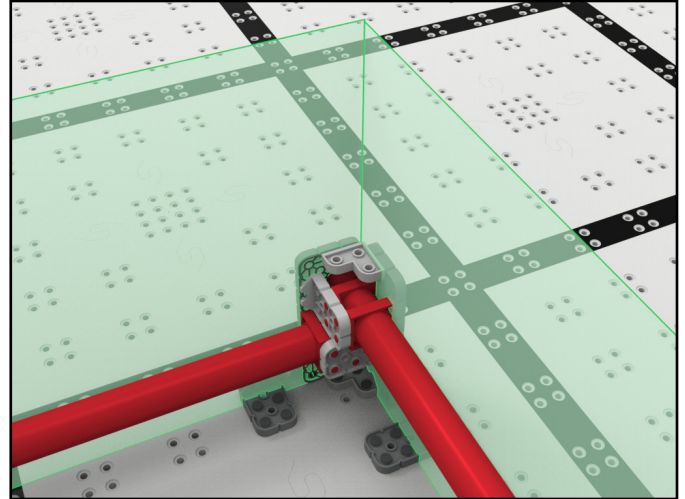

Figure 9: The boundaries of the Supply Zone.

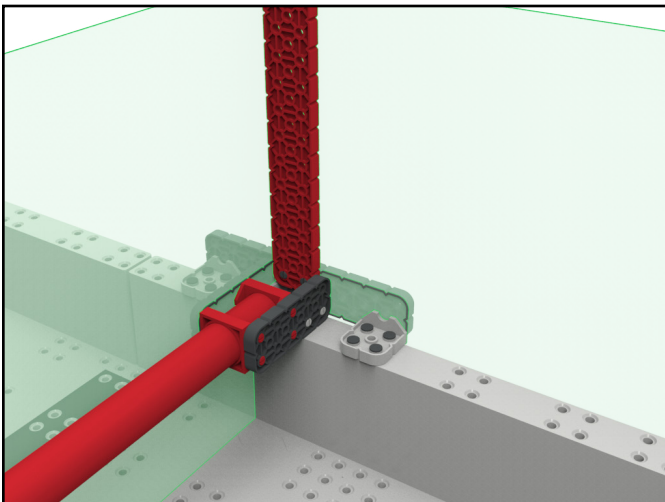

Figure 10: The boundaries of the Supply Zone.

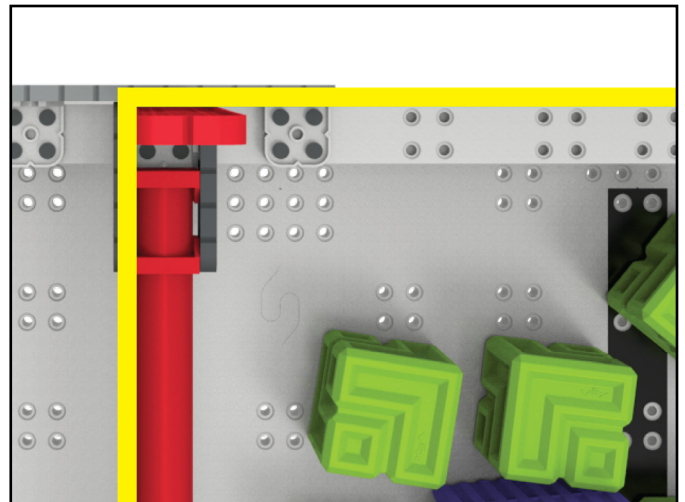

Figure 11: The boundaries of the Supply Zone.

Uniform - A *Goal* status. A *Goal* is considered *Uniform* if it meets the criteria set forth in rule <SC4>.

Scoring

Each <i>Block</i> Scored in a <i>Goal</i>	1 Point
Each <i>Uniform Goal</i>	10 Points
<i>Height Bonus</i>	10 Points per <i>Fill Level</i> (see <SC5>)
<i>Cleared Supply Zone</i>	20 Points
Each Red <i>Block</i> Removed from <i>Starting Peg</i>	5 Points
Each <i>Partially Parked Robot</i>	5 Points
Each <i>Fully Parked Robot</i>	10 Points
<i>Double Parked Bonus</i>	10 Points

<SC1> All Scoring statuses are evaluated **after the Match ends**, once all *Scored Blocks*, *Field Elements*, and *Robots* on the *Field* come to rest.

- a. This rule's intent is for *Driver* inputs and *Robot* motion to cease at the end of the *Match*, when the *Match* timer reaches 0:00. A pre-programmed routine which causes *Robot* motion to continue after the end of the *Match* would violate the spirit of this rule. Any Scoring which takes place after the *Match* due to *Robots* continuing to move will not count.

<SC2> All Scoring statuses are evaluated **visually by a Head Referee**, to the best of their ability within the context of a given *Match*/event.

- a. Referees and other event staff are not allowed to review any videos or pictures from the *Match*. See <T3>.
- b. If there is a concern regarding the score of a *Match*, only the *Drivers* from that *Match*, not an *Adult*, may share their questions with the *Head Referee*. See <T3>.

Note: In cases where a Scoring status is "too close to call," Teams will be given the "benefit of the doubt," and the higher of the two possible Scoring statuses should be assigned. Head Referees will not be expected or required to define a perfect horizontal plane or check imperceptibly small measurements.

<SC3> A **Block is considered Scored in a Goal** if it meets the following criteria:

- a. The *Block* is not contacting any *Robots*.
- b. The *Block* is at least partially contained within the infinite vertical projection of the outside surfaces of a *Goal*.
- c. The *Block* is either contacting the *Floor* within the *Goal* (i.e., at *Fill Level* 1), or transitively contacting the *Floor* via other *Scored Blocks*.

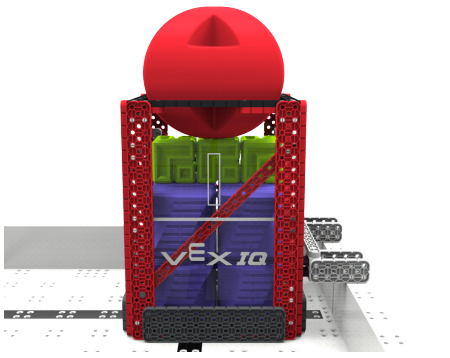
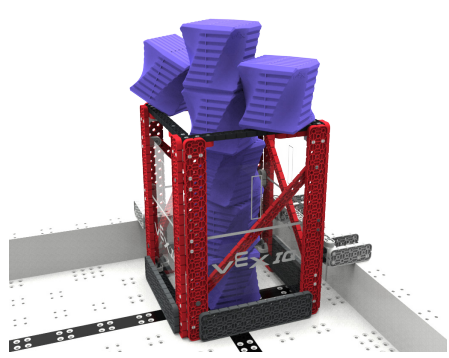
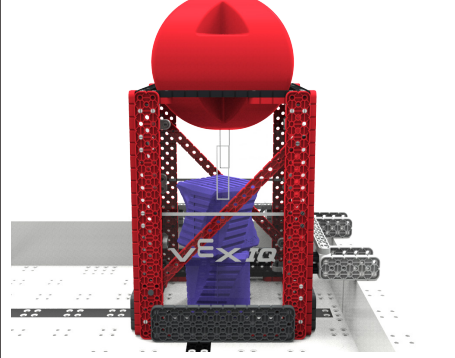
		
<p>Yes, all Scored</p>	<p>Yes, all Scored</p>	<p>The red <i>Block</i> is not Scored, because it is not transitively contacting the <i>Floor</i> within the <i>Goal</i>.</p>

<SC4> A **Goal is considered Uniform** if it meets the following criteria:

- a. At least two (2) *Blocks* are Scored in the *Goal*.
- b. All *Blocks* which are Scored in the *Goal* are of the same type.

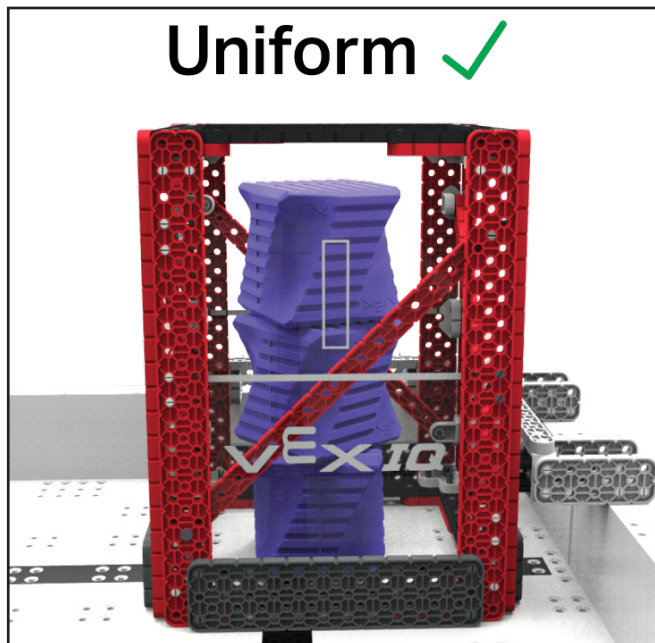

Figure 12: This Goal would be considered Uniform, because it contains at least 2 Blocks, all of which are the same type.



Figure 13: This Goal would not be considered Uniform, because not all of the Blocks Scored inside it are the same type.

<SC5> A **Height Bonus** is awarded for the highest *Fill Level* shared by all three *Goals*. If the *Fill Levels* meet the criteria for multiple *Height Bonuses*, only the highest of those Bonuses will be awarded.

If all Goals have a Fill Level of...	...then the <i>Height Bonus</i> is
1 or higher	10 points
2 or higher	20 points
3	30 points

In cases where a *Fill Level* is "too close to call," *Teams* will be given the "benefit of the doubt," and the higher of the two possible *Fill Levels* should be assigned. *Head Referees* will not be expected or required to define a perfect horizontal plane within a *Goal* or check imperceptibly small measurements.

<SC6> **Goal Scoring Examples:**

Example 1

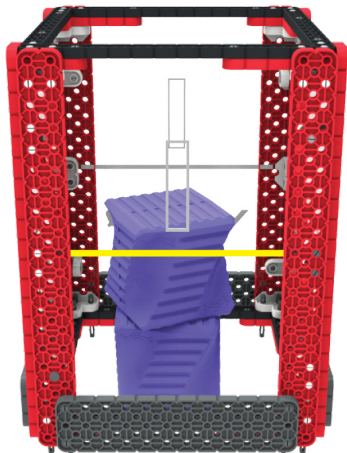

Fill Level: 2
Uniform: Yes

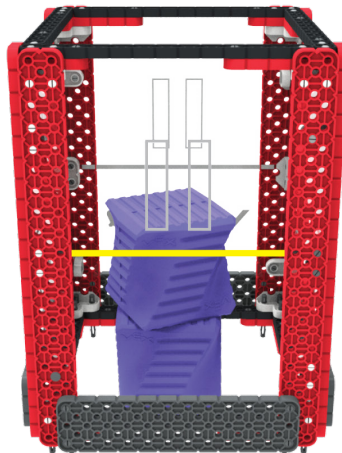

Fill Level: 2
Uniform: Yes



Fill Level: 2
Uniform: Yes

Highest common Fill Level: 2

All three *Goals* reached *Fill Level 2*, and all three *Goals* are considered *Uniform*.

Total # *Blocks*: 6
Height Bonus: 20
Total *Uniform Bonus*: 30
Total: 56

Example 2

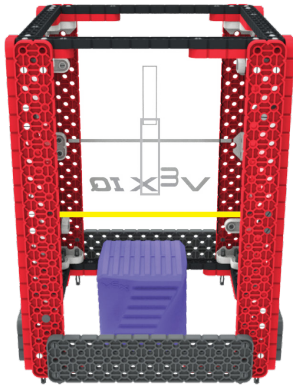

Fill Level: 1
Uniform: No

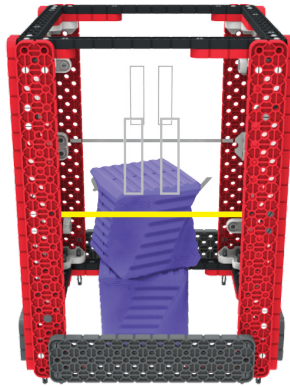

Fill Level: 2
Uniform: Yes

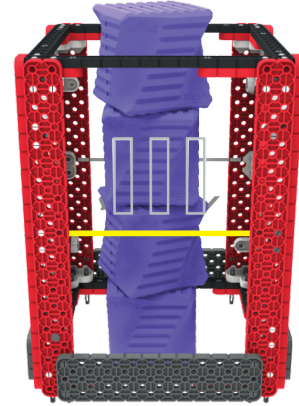

Fill Level: 3
Uniform: Yes

Highest common Fill Level: 1

Even though *Goals II* and *III* reached higher *Fill Levels*, the overall *Height Bonus* is still only 10 points because of *Goal I's Fill Level*.

Goal I is not considered *Uniform* because it only contains one *Block*.

Total # *Blocks*: 7
Height Bonus: 10
Total *Uniform Bonus*: 20
Total: 37

Example 3

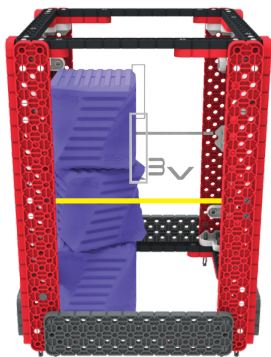

Fill Level: 2
Uniform: Yes

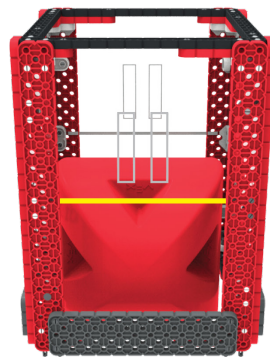

Fill Level: 2
Uniform: No



Fill Level: 2
Uniform: No

Highest common Fill Level: 2

All three *Goals* reached *Fill Level 2*.

Goal II is not considered *Uniform* because it only contains one *Block*.

Goal III is not considered *Uniform* because it has multiple types of *Blocks* in it.

Total # *Blocks*: 13
Height Bonus: 20
Total *Uniform Bonus*: 10
Total: 43

<SC7> Referees will verify if a **Robot is Fully or Partially Parked** by sliding a right-angle tool (such as a VEX IQ beam/plate) along the outside edge of the red PVC pipe or the *Field Perimeter*.

Note: Parking is evaluated independently of all other scoring statuses. For example, the Supply Zone does not need to be Cleared in order for Robots to be considered Parked.

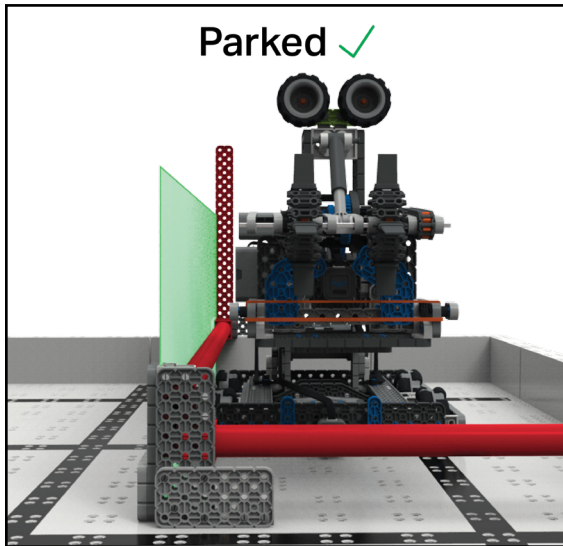

Figure 14: This Robot would be considered as *Parked*, because it is completely within the boundaries of the *Supply Zone*.

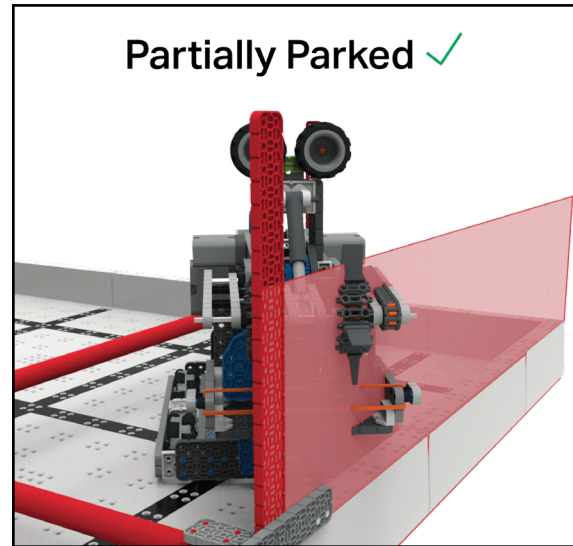

Figure 15: This Robot would be considered as *Partially Parked*, because it is not completely within the boundaries of the *Supply Zone*.

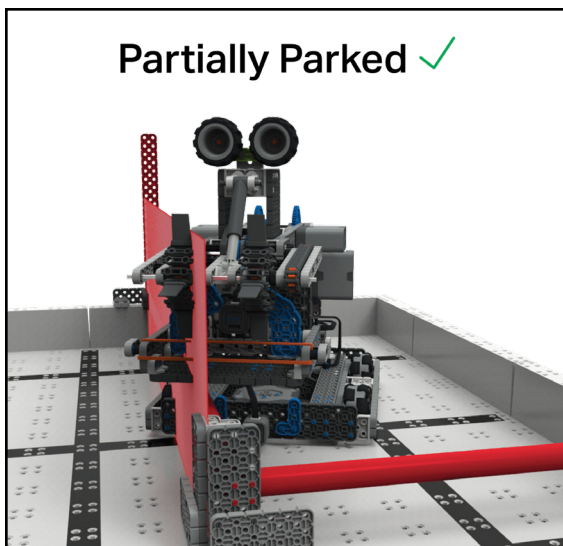

Figure 16: This Robot would be considered as *Partially Parked*, because it is not completely within the boundaries of the *Supply Zone*.

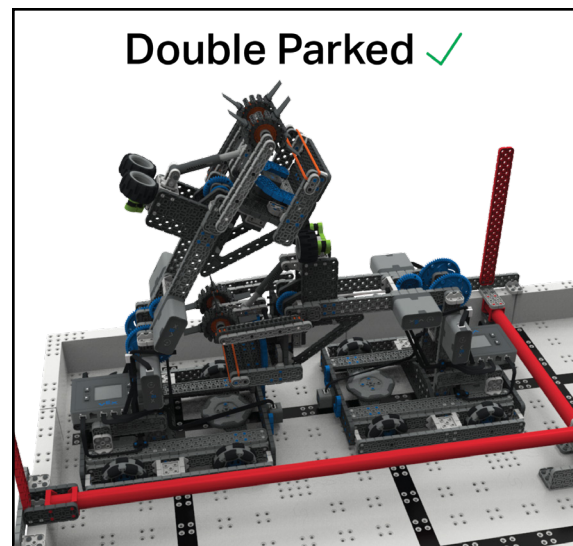

Figure 17: These Robots would be considered as *Double Parked*, because they are both completely within the boundaries of the *Supply Zone*.

Safety Rules

<S1> Stay safe, don't damage the Field. If, at any time, the *Robot* operation or *Team* actions are deemed unsafe or have damaged any *Field Elements* or *Blocks*, the offending *Team* may be *Disabled* and/or *Disqualified* at the *Head Referee's* discretion. The *Robot* will require re-inspection before it may again take the *Field*.

<S2> Students must be accompanied by an Adult. No *Student* may attend a VEX IQ Robotics Competition event without a responsible *Adult* supervising them. The *Adult* must obey all rules and be careful to not violate student-centered policies, but must be present at the event in the case of an emergency. *Violations* of this rule may result in removal from the event.

General Game Rules

<G1> Treat everyone with respect. All *Teams* are expected to conduct themselves in a respectful and professional manner while competing in VEX IQ Robotics Competition events. If a *Team* or any of its members (*Students* or any *Adults* associated with the *Team*) are disrespectful or uncivil to event staff, volunteers, or fellow competitors, they may be *Disqualified* from a current or upcoming *Match*. *Team* conduct pertaining to <G1> may also impact a *Team's* eligibility for judged awards. Repeated or extreme violations of <G1> could result in a *Team* being *Disqualified* from an entire event, depending on the severity of the situation.

This rule exists alongside the REC Foundation Code of Conduct. Violation of the Code of Conduct can be considered a *Major Violation* of <G1> and can result in *Disqualification* from a current *Match*, an upcoming *Match*, an entire event, or (in extreme cases) an entire competition season. The Code of Conduct can be found at <https://viqc-kb.recf.org/hc/en-us/articles/9778593540247-Code-of-Conduct>.

More information regarding the event Code of Conduct process can be found at: <https://vrc-kb.recf.org/hc/en-us/articles/16943747839383-Event-Code-of-Conduct-Process>

We all can contribute to creating a fun and inclusive event experience for all event attendees. Some examples include:

When dealing with difficult and stressful situations, it is...

- Okay for *Teams* to be gracious and supportive when your *Alliance* partner makes a mistake.
- Not okay for *Teams* to harass, tease, or be disrespectful to your *Alliance* partner when a *Match* does not go your way.

When a *Team* does not understand a *Match* ruling or score, it is...

- Okay for *Drivers* to consult with a *Head Referee* to discuss a ruling per the process outlined in <T3> in a calm and respectful manner.

- Not okay for *Drivers* to continue arguing with the *Head Referee* after a decision has been finalized, or for *Adults* to approach a *Head Referee* with ruling/scoring concerns.

When *Teams* are getting ready for an upcoming *Match*, it is...

- Okay for *Teams* in an *Alliance* to develop a game strategy that utilizes the strengths of both *Robots* to cooperatively solve the game.
- Not okay for one *Team* in an *Alliance* to ask another *Team* to sit in a corner during the *Match* or to intentionally play beneath their abilities.

Violation Notes: All Violations of <G1> are considered Major Violations and should be addressed on a case-by-case basis. Teams at risk of a <G1> Violation due to multiple disrespectful or uncivil behaviors will usually receive a "final warning", although the Head Referee is not required to provide one.

<G2> VIQRC is a student-centered program. *Adults* may assist *Students* in urgent situations, but *Adults* may never work on or program a *Robot* without *Students* on that *Team* being present and actively participating. *Students* must be prepared to demonstrate an active understanding of their *Robot's* construction and programming to judges or event staff.

Some amount of *Adult* mentorship, teaching, and / or guidance is an expected and encouraged facet of VEX competitions. No one is born an expert in robotics! However, obstacles should always be viewed as teaching opportunities, not tasks for an *Adult* to solve without *Students* present and actively participating.

When a mechanism falls off, it is...

- Okay for an *Adult* to help a *Student* investigate why it failed, so it can be improved.
- Not okay for an *Adult* to put the *Robot* back together.

When a *Team* encounters a complex programming concept, it is...

- Okay for an *Adult* to guide a *Student* through a flowchart to understand its logic.
- Not okay for an *Adult* to write a premade command for that *Student* to copy / paste.

During *Match* play, it is...

- Okay for an *Adult* to provide cheerful, positive encouragement as a spectator.
- Not okay for an *Adult* to explicitly shout step-by-step commands from the audience.

This rule operates in tandem with the REC Foundation Student Centered Policy, which is available on the REC Foundation website for *Teams* to reference throughout the season:

<https://viqc-kb.recf.org/hc/en-us/articles/9778591033879-Student-Centered-Policy>

Violation Notes: Potential Violations of this rule will be reviewed on a case-by-case basis. By definition, all Violations of this rule become Score Affecting as soon as a Robot which was built by an Adult scores points in a Match.

<G3> Use common sense. When reading and applying the various rules in this document, please remember that common sense always applies in the VEX IQ Robotics Competition.

Some examples may include:

- If there is an obvious typographical error (such as “per <T5>” instead of “per <G5>”), this does not mean that the error should be taken literally until corrected in a future update.
- Understand the realities of the VEX IQ *Robot* construction system. For example, if a *Robot* could hover above the *Field* for a whole *Match*, that would create loopholes in many of the rules. But... they can't. So... don't worry about it.
- When in doubt, if there is no rule prohibiting an action, it is generally legal. However, if you have to ask whether a given action would violate <S1>, <G1>, or <T1>, then that's probably a good indication that it is outside the spirit of the competition.
- In general, *Teams* will be given the “benefit of the doubt” in the case of accidental or edge-case rules infractions. However, there is a limit to this allowance, and repeated or strategic infractions will still be penalized.

<G4> The Robot must represent the skill level of the Team. Each *Team* must include *Drivers*, *Programmer(s)*, *Designer(s)*, and *Builder(s)*. No *Student* may fulfill any of these roles for more than one VEX IQ Robotics Competition *Team* in a given competition season. *Students* may have more than one role on the *Team*, e.g. the *Designer* may also be the *Builder*, the *Programmer* and a *Driver*.

- a. *Team* members may move from one *Team* to another for non-strategic reasons outside of the *Team's* control.
 - i. Examples of permissible moves may include, but are not limited to, illness, changing schools, conflicts within a *Team*, or combining/splitting *Teams*.
 - ii. Examples of strategic moves in *Violation* of this rule may include, but are not limited to, one *Programmer* “switching” *Teams* in order to write the same program for multiple *Robots*, or one *Student* writing the Engineering Notebook for multiple *Teams*.
 - iii. If a *Student* leaves a *Team* to join another *Team*, <G4> still applies to the *Students* remaining on the previous *Team*. For example, if a *Programmer* leaves a *Team*, then that *Team's Robot* must still represent the skill level of the *Team* without that *Programmer*. One way to accomplish this would be to ensure that the *Programmer* teaches or trains a “replacement” *Programmer* in their absence.

- b. When a *Team* qualifies for a Championship event (e.g., States, Nationals, Worlds, etc.) the *Students* on the *Team* attending the Championship event are expected to be the same *Students* on the *Team* that was awarded the spot. *Students* can be added as support to the *Team*, but may not be added as *Drivers* or *Programmers* for the *Team*.
 - i. An exception is allowed if one (1) *Driver* and/or one (1) *Programmer* on the *Team* cannot attend the event. The *Team* can make a single substitution of a *Driver* or *Programmer* for the Championship event with another *Student*, even if that *Student* has competed on a different *Team*. This *Student* will now be on this new *Team* and may not substitute back to the original *Team*.

Violation Notes: Violations of this rule will be evaluated on a case-by-case basis, in tandem with the REC Foundation Student Centered Policy as noted in <G2>, and the REC Foundation Code of Conduct as noted in <G1>.

Event Partners should bear in mind <G3>, and use common sense when enforcing this rule. It is not the intent to punish a *Team* who may change *Team* members over the course of a season due to illness, changing schools, conflicts within a *Team*, etc.

Event Partners and referees are not expected to keep a roster of any *Student* who has ever been a *Driver* for one day. This rule is intended to block any instance of loaning or sharing *Team* members for the sole purpose of gaining a competitive advantage.

<G5> Robots begin the Match in the starting size. At the beginning of a *Match*, each *Robot* must fit within an 11" wide x 20" long x 15" high (279mm x 508mm x 381mm) volume, as checked during inspection per <R4>.

Violation Notes: Any Violation of this rule will result in the Robot being removed from the Field prior to the start of the Match; rules <R3d> and <T6> will apply until the situation is corrected. They will not receive a Disqualification, but they will not be permitted to play in the Match.

<G6> Keep your Robot together. *Robots* may not intentionally detach parts or leave mechanisms on the *Field* during any *Match*. Parts that become unintentionally detached from the *Robot* are no longer considered to be part of the *Robot* and can be either left on the *Field* or collected by a *Driver* (utilizing <G10>).

Note: Adding or replacing mechanisms on a Robot mid-Match (e.g. during a <G10> interaction) is considered a Violation of the intent and spirit of this rule.

<G7> Don't damage the Field. *Robot* interactions which damage the *Field* or any *Field Elements* are prohibited. For the purpose of this rule, "damage" is defined as anything which requires repair in order to begin the next *Match*, such as causing part of a *Goal* to detach from the *Field*.

Teams are responsible for the actions of their Robots at all times, especially when interacting with Goals and the Supply Zone. If a Team chooses to repeatedly ram full-speed into a Goal, it will be hard to convince a Head Referee that any damage caused was "accidental."

Violation Notes:

- *In most cases, accidental Field damage should only be considered a Minor Violation / formal warning*
- *Accidentally dislodging a Starting Peg is not considered a Major Violation*
- *Egregious, intentional, or repeated accidental / Minor Violations may escalate to a Major Violation at the Head Referee's discretion*

<G8> Drivers drive your Robot, and stay in the Driver Station. During a Match, Robots may only be operated by that Team's Drivers and/or software running on the Robot's control system. Drivers must remain in their Driver Station, except when legally interacting with their Robot as per <G10>.

Drivers are prohibited from any of the following actions during a Match:

- a. Bringing/using any sort of communication devices into the Driver Station. Devices with communication features turned off (e.g., a phone in airplane mode) are allowed.
- b. Standing or sitting on any sort of object during a Match, regardless of whether the Field is on the floor or elevated.
- c. Materials used outside of the 1:00 Match time are permitted, provided that no other rules are violated. Examples could include a bin to help carry the Robot to the Field, or VEX IQ parts used to help align the Robot at the start of the Match.

Note: Drivers are the only Team members that are allowed to be in the Driver Station during a Match. Adults (other than event staff) are not permitted to be in the Driver Station during a Match.

Violation Notes: Major Violations of this rule are not required to be Score Affecting, and could invoke Violations of other rules, such as <G1>, <G2>, or <G11>.

<G9> Hands out of the Field. Drivers are prohibited from making intentional contact with any Field Element, Block, or Robot during a Match, except for the allowances in <G10>, <RSC5> and/or <SG3>.

<G10> Handling the Robot mid-match is allowed under certain circumstances. If a Robot goes completely outside the playing Field, gets stuck, tips over, or otherwise requires assistance, the Team's Drivers may retrieve & reset the Robot. To do so, they must do the following:

1. Signal the Referee by placing their VEX IQ Controller on the ground.

2. Any *Blocks* being controlled by the *Robot* while being handled must be removed from the *Field*.
 - a. In the context of this rule, “controlled” implies that the *Robot* was manipulating the *Block*, and not simply touching it. For example, if the *Block* moves with the *Robot* either vertically or while turning, then the *Robot* is “controlling” the *Block*.
3. The *Robot* must be placed back into a legal position that meets the criteria listed in <SG1> (i.e., contacting the *Field Perimeter*, not contacting any *Blocks*, etc).

If the *Drivers* cannot reach the *Robot* due to the *Robot* being in the center of the *Field*, the *Drivers* may ask the *Head Referee* to pick up the *Robot* and hand it to the *Drivers* for placement according to the conditions above.

Violation Notes: This rule is intended to allow Teams to fix damaged Robots or help get their Robots “out of trouble.” Strategically exploiting this rule may be considered a Minor Violation or Major Violation at the Head Referee’s discretion.

<G11> A Team’s two Drivers switch Controllers midway through the Match. In a given *Match*, up to two (2) *Drivers* may be in the *Driver Station* per *Team*. The two *Drivers* must switch their controller between twenty-five seconds (0:25) and thirty-five seconds (0:35) remaining in the *Match*.

- a. No *Driver* shall operate a *Robot* for more than thirty-five seconds (0:35).
- b. The second *Driver* may not touch their *Team’s* controls until the controller is passed to him/her.
- c. Once the controller is passed, the first *Driver* may no longer touch their *Team’s* controls.

Note: If only one Driver is present (i.e., the Team has not exercised the allowance in <G4>), this rule still applies, and they must cease Robot operation after the first thirty-five (0:35) seconds of the Match.

Violation Notes: At a minimum, any Violation of this rule is considered a Minor Violation. Whether it escalates to a Major Violation or not is dependent upon the Head Referee’s judgment regarding:

- *Prior warnings or Violations*
- *Any Score Affecting actions that were a direct result of the Violation, such as the first Driver scoring additional points after 35 seconds of driving*

Note: The 2024-2025 and 2025-2026 VIQRC games will include a third Drive Team member. This will be a non-*Driver* role that will focus on human “match load” interactions with Game Objects. More information will be available when the 2024-2025 VIQRC Game Manual is released in May 2024.

Specific Game Rules

<SG1> **Pre-match setup.** At the beginning of a *Match*, each *Robot* must meet the following criteria:

1. Not contacting any *Blocks*, *Goals* or their supporting structure, *Starting Pegs*, or other *Robots*.
2. Fit within an 11" wide x 20" long x 15" high (279mm x 508mm x 381mm) volume, as checked during inspection per <R3>.
3. Contacting the inside and/or top face of the *Field Perimeter* wall that is between *Goals* I and II. See Figure 18.
4. Have no motors or other mechanisms in motion or "running" until the *Match* begins. Pre-charging a pneumatic system (i.e., having the Pneumatic Pump running prior to the *Match*) is the only permitted exception to this rule.

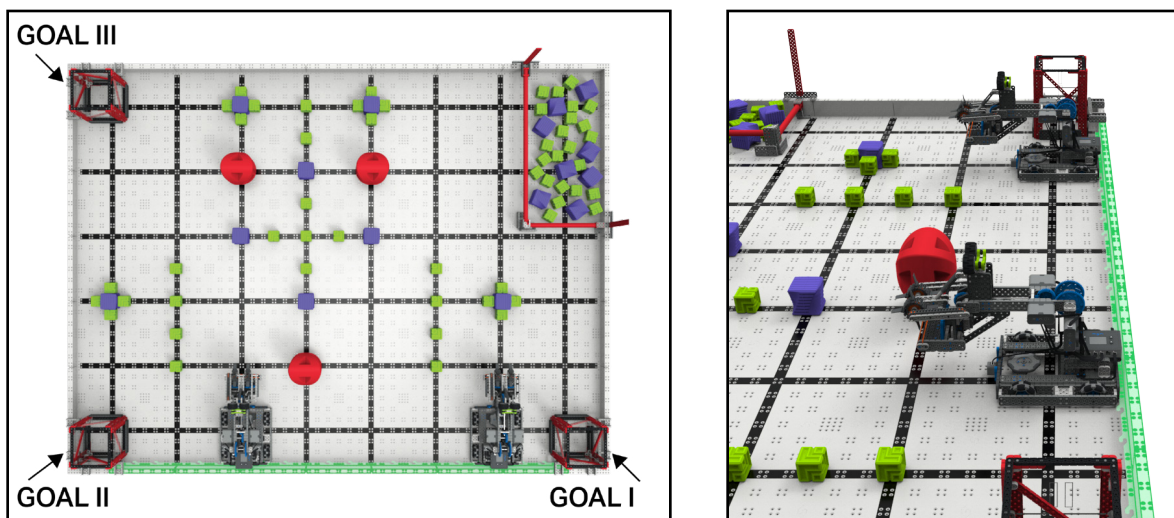

Figure 18: Robots in a legal pre-Match starting position.

Violation Notes: Any Violation of this rule will result in the Robot being removed from the Field prior to the start of the Match; rules <R3d> and <T6> will apply until the situation is corrected. They will not receive a Disqualification, but they will not be permitted to play in the Match.

Note: There are no specific starting positions, as long as the above criteria are met. Head Referees may ask Teams to temporarily move their Robot between two of the black lines on the Field for a size check, but there is no requirement for them to start the Match in that location once the size has been verified.

<SG2> **Horizontal expansion is limited during a Match.** Robots may not expand horizontally beyond the 11" x 20" starting dimension limit at any time during a *Match*. This "horizontal" measurement is made relative to the Robot's starting orientation; it is not "absolutely horizontal" relative to the Floor. See Figure 19.

Note: There are no restrictions on vertical expansion.

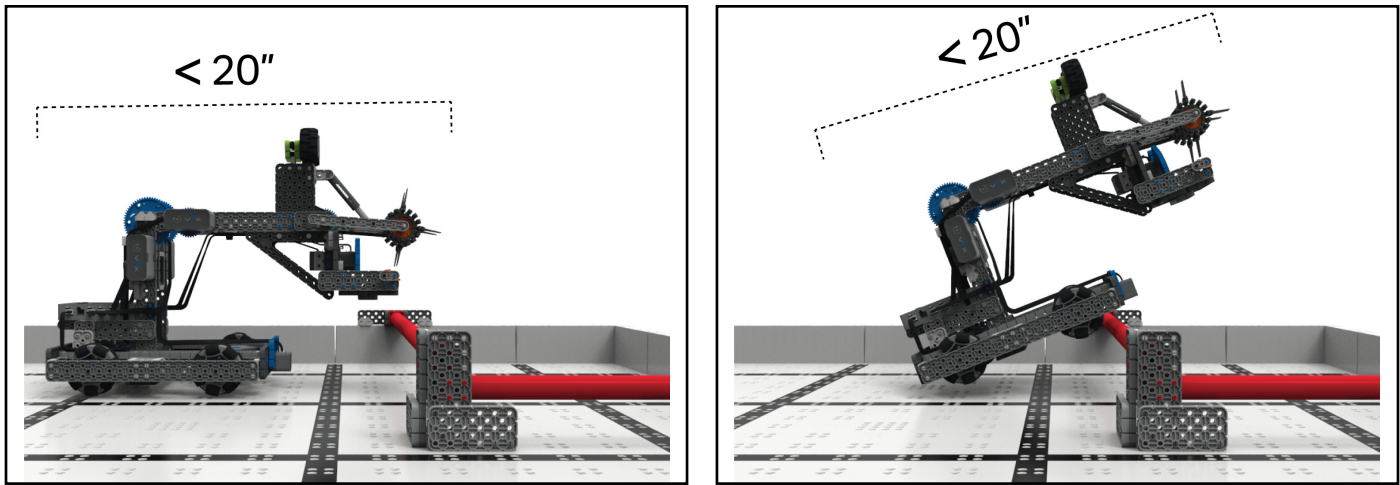

Figure 19: Examples of how a Robot should be measured horizontally.

<SG3> Keep Blocks in the Field. Blocks that leave the *Field* during a *Match* may be returned to the *Supply Zone* by a *Driver* or *Referee*.

- "Leaving the *Field*" means that a *Block* is outside of the *Field Perimeter* and no longer in contact with the *Field*, *Field Elements*, other *Blocks*, or *Robots*. If *Blocks* are removed from a *Robot* during a <G10> interaction, these *Blocks* are considered "out of the *Field*" as soon as they are no longer in contact with any *Robots*.
- Blocks* may not be placed in contact with any *Robots*
- Moving or disturbing other *Blocks* during this action may be considered a Violation of rule <G9>. If a *Block* is unable to be returned without disturbing other *Blocks*, it should remain outside of the *Field* until it can be legally placed.
- Any *Blocks* which remain outside of the *Field* at the end of a *Match* will be considered "in" the *Supply Zone* (i.e., the *Supply Zone* will not be eligible to be *Cleared*).

Note: If a Block is unable to be returned to the Supply Zone without disturbing or moving other Blocks, it may remain outside of the Field.

If a *Block* is on its way out of the *Field* (as determined by the *Head Referee*), but is deflected back into the field by a *Driver*, field monitor, ceiling/wall, or other external factor, <SG3> would still apply. This *Block* should be considered "out of the *Field*" and removed or returned to the *Supply Zone* by a *Head Referee*. If the redirection occurred due to contact with a *Driver*, it will be at the *Head Referee's* discretion whether <G9> or <SG3> should apply.

<SG4> Blocks are randomly loaded in the Supply Zone. Prior to each *Match*, the *Supply Zone* will be filled randomly with eight (8) Purple *Blocks* and twenty-three (23) Green *Blocks*.

- Blocks* will be randomly mixed by a field reset volunteer and/or the *Head Referee*.
- Blocks* must be placed such that one face of each *Block* is "flat" on the *Floor* (i.e. not "stacked" or "tilted"). See images throughout this Game Manual for examples.
- Team* members may not touch *Blocks* in the *Supply Zone* during pre-*Match* setup. Any contact will result in a re-randomization of the *Supply Zone* by the *Head Referee*.

Section 2

The Robot

Description

Every *Robot* must pass a full inspection before being cleared to participate in the VEX IQ Robotics Competition. This inspection will ensure that all *Robot* rules and regulations are met. Initial inspections will typically take place during team check-in / practice time. Every *Team* should use the rules below as a guide to pre-inspect their *Robot* and ensure that it meets all requirements.

Inspection Rules

<R1> One Robot per Team. Only one (1) *Robot* will be allowed to participate per *Team* at a given event. Though it is expected that *Teams* will make changes to their *Robots* at the event, a *Team* is limited to only one (1) *Robot*, and a given *Robot* may only be used by (1) *Team*. The VEX IQ system is intended to be a mobile robotics design platform. As such, a VEX IQ Robotics Competition *Robot*, for the purposes of the VEX IQ Robotics Competition, has the following subsystems:

- Subsystem 1: Mobile robotic base including wheels, tracks, or any other mechanism that allows the *Robot* to navigate the majority of the flat playing *Field* surface. For a stationary *Robot*, the robotic base without wheels would be considered Subsystem 1.
- Subsystem 2: Power and control system that includes a VEX IQ legal battery, a VEX IQ control system, and associated Smart Motors for the mobile robotic base.
- Subsystem 3: Additional mechanisms (and associated Smart Motors) that allow manipulation of *Blocks* or navigation/manipulation of *Field Elements*.

Given the above definitions, a minimum *Robot* for use in any VEX IQ Robotics Competition event (including Skills Challenges) must consist of subsystems 1 and 2 above. Thus, if you are swapping out an entire subsystem 1 or 2, you have now created a second *Robot* and are no longer legal.

- *Teams* may not compete with one *Robot* while a second is being modified or assembled at a competition.
- *Teams* may not have an assembled second *Robot* on hand at a competition that is used to repair or swap parts with the first *Robot*.
- *Teams* may not switch back and forth between multiple *Robots* during a competition. This includes using different *Robots* for Skills Challenge, *Qualification Matches*, and/or *Finals Matches*.
- Multiple *Teams* may not use the same *Robot*. Once a *Robot* has competed under a given *Team* number at an event, it is "their" *Robot*; no other *Teams* may compete with it for the duration of the competition season.

The intent of <R1a>, <R1b>, and <R1c> is to ensure an unambiguous level playing field for all *Teams*. *Teams* are welcome (and encouraged) to improve or modify their *Robots* between events, or to collaborate with other *Teams* to develop the best possible game solution.

However, a *Team* who brings and/or competes with two separate *Robots* at the same tournament has diminished the efforts of a *Team* who spent extra design time making sure that their one *Robot* can accomplish all of the game's tasks. A multi-*Team* organization that shares a single *Robot* has diminished the efforts of a multi-*Team* organization that puts in the time, effort, and resources to undergo separate individual design processes and develop their own *Robots*.

To help determine whether a *Robot* is a "separate *Robot*" or not, use the Subsystem definitions found in <R1>. Above that, use common sense as referenced in <G3>. If you can place two complete and legal *Robots* on a table next to each other, then they are two separate *Robots*. Trying to decide if changing a pin, a wheel, or a motor constitutes a separate *Robot* is missing the intent and spirit of this rule.

<R2> Robots must represent the Team's skill level. The *Robot* must be designed, built, and programmed by members of the *Team*. *Adults* are permitted to mentor and teach design, building, and programming skills to the *Students* on the *Team*, but may not design, build, or program that *Team's Robot*.

In VIQRC, we expect *Adults* to teach fundamental *Robot* principles like linkages, drive-trains, and manipulators, then allow the *Students* to determine which designs to implement and build on their *Robot*.

Similarly, *Adults* are encouraged to teach the *Students* how to code various functions involving applicable sensors and mechanisms, then have the *Students* program the *Robot* from what they have learned.

<R3> Robots must pass inspection. The *Team's Robot* must pass inspection before being allowed to participate in any *Matches*. Noncompliance with any *Robot* design or construction rule will result in removal from *Matches* or *Disqualification* of the *Robot* at an event until the *Robot* is brought back into compliance, as described in the following subclauses.

- a. Significant changes to a *Robot*, such as a partial or full swap of Subsystem 3, must be re-inspected before the *Robot* may compete again.
- b. All possible functional *Robot* configurations must be inspected before being used in competition.
- c. *Teams* may be asked to submit to random spot inspections by *Head Referees*. Refusal to submit will result in *Disqualification*.
 - i. If a *Robot* is determined to not be legal before a *Match* begins, the *Robot* will be removed from the *Field*. A *Driver* may remain so that the *Team* does not get assessed a "no-show" (per <T5>).

- d. *Robots* which have not passed inspection (i.e., that are in *Violation* of one or more *Robot* rules) will not be permitted to play in any *Matches* until they have done so. <T6> will apply to any *Matches* that occur until the *Robot* has passed inspection.
- e. If a *Robot* has passed inspection, but is later found to be in *Violation* of a *Robot* rule during or immediately following a *Match*, then they will be Disqualified from that *Match* and <R3d> / <T6> will apply until the *Violation* is remedied and the *Team* is re-inspected.
- f. All inspection rules are to be enforced at the discretion of the *Head Referee* within a given event. *Robot* legality at one event does not automatically imply legality at future events. *Robots* which rely on "edge-case" interpretations of subjective rules, such as whether a decoration is "non-functional" or not, should expect additional scrutiny during inspection.

<R4> **Starting configuration.** At the start of each *Match*, the *Robot* must be able to satisfy the following constraints:

- a. Only be contacting the *Floor* and the *Field Perimeter*.
- b. Fit within an 11" x 20" x 15" (279.4mm x 508mm x 381.0mm) volume.
- c. The starting configuration of the *Robot* at the beginning of a *Match* must be the same as a *Robot* configuration inspected for compliance, and within the maximum allowed size.
 - i. *Teams* using more than one possible *Robot* configuration at the beginning of *Matches* must tell the Inspector(s) and have the *Robot* inspected in its largest configuration(s).
 - ii. A *Team* may NOT have its *Robot* inspected in one configuration and then place it in an uninspected configuration at the start of a *Match*.

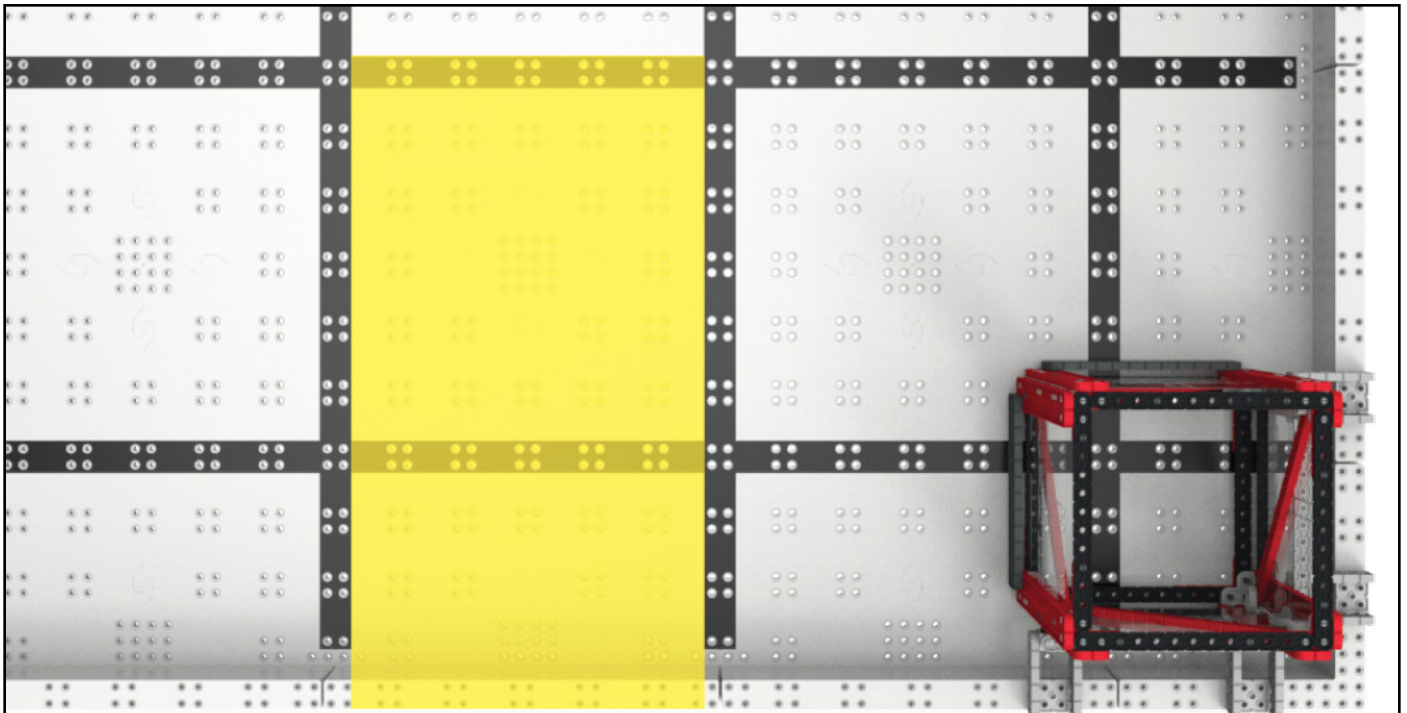

Figure 20: The approximate starting size that a *Robot* should start the *Match* in.

<R5> Prohibited items. The following types of mechanisms and components are NOT allowed:

- a. Those that could potentially damage *Field Elements* or *Blocks*.
- b. Those that could potentially damage or entangle other *Robots*.

<R6> VEX IQ product line. *Robots* may be built ONLY from official *Robot* components from the VEX IQ product line, unless otherwise specifically noted within these rules.

- a. Official VEX IQ products are ONLY available from VEX Robotics. To determine whether a product is "official" or not, consult www.vexiq.com.
- b. If an Inspector or event official questions whether something is an official VEX IQ component, the *Team* will be required to provide documentation to an inspector that proves the component's source. Such documentation may include receipts, part numbers, or other printed documentation.
- c. Only VEX IQ components specifically designed for use in *Robot* construction are allowed. Using additional components outside their typical purpose is against the intent of the rule (i.e., please don't try using VEX IQ apparel, *Team* or event support materials, packaging, *Field Elements*, or other non-*Robot* products on a VEX IQ Robotics Competition *Robot*).
- d. Products from the VEX V5, VEX CTE, VEX EXP, Cortex, or VEXpro product lines cannot be used for *Robot* construction. However, products from the VEX V5 product line that are also cross-listed as part of the VEX IQ product line are legal. A "cross-listed" product is one which can be found in both the VEX IQ and VEX V5 sections of the VEX Robotics website.
- e. Mechanical/structural components from the VEX Robotics by HEXBUG* product line are legal for *Robot* construction. However, electrical components from the VEX Robotics by HEXBUG product line are illegal for *Robot* construction.
- f. Mechanical/structural components from the VEX GO product line are legal for *Robot* construction. However, electrical components from the VEX GO product line are illegal for *Robot* construction.
- g. Official Robotics components from the VEX IQ product line that have been discontinued are still legal for *Robot* use. However, *Teams* must be aware of <R6b>.
- h. Functional 3D printed components, such as replicas of legal VEX IQ parts or custom designs, are not legal for *Robot* use.
- i. Additional VEX IQ products that are released during the season are legal for use, unless otherwise noted on their product pages and/or in the [VEX IQ Robotics Competition Legal Parts Appendix](#).
- j. VEX IQ Smart Cables may only be used for connecting legal electronic devices to the VEX IQ Robot Brain.

Note: A comprehensive list of legal parts can be found in the VEX IQ Robotics Competition Legal Parts Appendix, at <https://www.vexrobotics.com/iq/competition/viqc-current-game>. This Appendix is updated as needed if/when new VEX IQ parts are released, and may not coincide with scheduled Game Manual updates.

* The HEXBUG brand is a registered trademark belonging to Spin Master Corp

<R7> Non-VEX IQ components. *Robots* are allowed to use the following additional “non-VEX IQ” components:

- a. Rubber bands that are identical in length and thickness to those included in the VEX IQ product line (#32, #64 & #117B).
- b. $\frac{1}{8}$ ” metal shafts from the VEX V5 product line.

<R8> Decorations are allowed. *Teams* may add non-functional decorations, provided that they do not affect *Robot* performance in any significant way or affect the outcome of the *Match*. These decorations must be in the spirit of the competition. Inspectors will have final say in what is considered “non-functional.” Unless otherwise specified below, non-functional decorations are governed by all standard *Robot* rules.

- a. Decorations must be in the spirit of an educational competition.
- b. To be considered “non-functional,” any decorations must be backed by legal materials that provide the same functionality. For example, a giant decal cannot be used to prevent *Blocks* from falling out of the *Robot* unless it is backed by VEX IQ material. A simple way to check this is to determine if removing the decoration would impact the performance of the *Robot* in any way.
- c. The use of non-toxic paint is considered a legal non-functional decoration. However, any paint being used as an adhesive or to impact how tightly parts fit together would be classified as functional.

Teams should be mindful of any non-functional decorations which could risk “distracting” *Alliance* partner *Robots’* Vision Sensor or other sensors.

<R9> Officially registered Team numbers must be displayed on Robot License Plates. To participate in an official VEX IQ Robotics Competition Event, a *Team* must first register on robotevents.com and receive a VEX IQ Robotics Competition Team Number.

This *Team* number must be legibly displayed on at least one (1) VEX IQ Robotics Competition *License Plate*. *Teams* may choose to use the official VEX IQ Robotics Competition *License Plate* (VEX Part Number 228-7401), or may create their own custom *License Plates*.

- a. *License Plates* must fulfill all inspection rules.
- b. *License Plates* must be clearly visible at all times. For example, *License Plates* must not be in a position that would be easily obstructed by a *Robot* mechanism during standard *Match* play.
- c. Any custom-made *License Plates* used must be the same length and height as the official *License Plate* (3.5” x 1.5” [88.9mm x 38.1mm]). They must not exceed the width of the official *License Plate* (0.25” [6.35mm]).
- d. Custom-made *License Plates* are considered non-functional decorations, and must therefore meet all of the criteria listed in <R8>. Therefore, 3D printed *License Plates* are permitted within these rules.

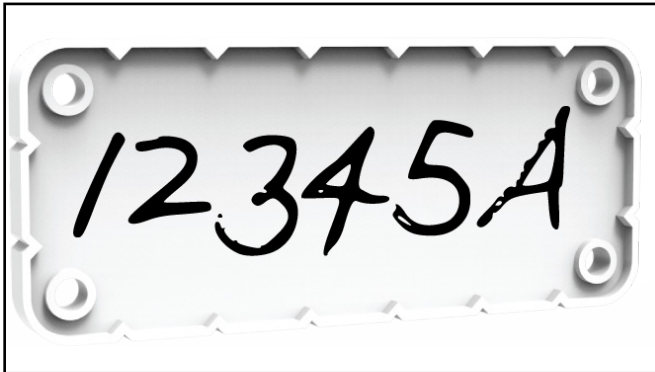

Figure 21: A VEX IQ Robotics Competition License Plate with a VEX IQ Robotics Competition Team Number written upon it.



Figure 22: An example of a legal custom License Plate.

<R10> Let it go after the Match is over. Robots must be designed to permit easy removal of Blocks from their Robot without requiring that the Robot have power or remote control after the Match is over.

<R11> Robot Brain. Robots are limited to one (1) VEX IQ Robot Brain.

- a. Robot Brains, microcontrollers, and other electronic components that are part of the VEX Robotics by HEXBUG, VEX GO, VEX EXP, VEX V5, VEX 123, or VEXpro product lines are not allowed.
 - i. The Robot AA Battery Holder (228-3493) is the only exception to this rule, per <R13>.
- b. If using a first generation VEX IQ Brain, Robots must use one (1) VEX IQ 900 MHz radio, VEX IQ 2.4 GHz radio, or VEX IQ Smart Radio in conjunction with their VEX IQ Robot Brain.
- c. The only legal method of driving the Robot during Teamwork Challenge Matches and Driving Skills Matches is the VEX IQ Controller.
- d. See <RSC5> and <RSC6> for more information about operating the Robot during Autonomous Coding Skills Matches.

<R12> Motors. Robots may use up to six (6) VEX IQ Smart Motors.

- a. Additional motors cannot be used on the Robot (even motors that aren't connected).

<R13> Batteries. The only allowable sources of electrical power for a VEX IQ Robotics Competition Robot are one (1) VEX IQ Robot Battery (first or second generation) or six (6) AA batteries via the Robot AA Battery Holder (228-3493).

- a. Additional batteries cannot be used on the Robot (even batteries that aren't connected).

- b. *Teams* are permitted to have an external power source (such as a rechargeable battery pack) plugged into their VEX IQ Controller during a *Match*, provided that this power source is connected safely and does not violate any other rules (such as <G8>).

Note: Although it is legal, the Robot AA Battery Holder (228-3493) is not recommended for use in the VEX IQ Robotics Competition.

<R14> Firmware. *Teams* must have their VEX IQ firmware (VEXos) up to date. *Teams* can download the latest version of VEXos at www.vexiq.com/vexos.

<R15> Modifications of parts. Parts may NOT be modified unless specifically listed as an exception in this rule. Examples of modifications include, but are not limited to, bending, cutting, sanding, gluing, or melting. The following exceptions are legal:

- a. Cutting metal VEX IQ or VEX V5 shafts to custom lengths.
- b. Bending parts which are intended to be flexible, such as string, rubber bands, or thin plastic sheets.
- c. Cutting VEX IQ pneumatic tubing to custom lengths.

<R16> Pneumatics. *Robots* using parts from the VEX IQ Pneumatics Kit (228-8795) must satisfy the following criteria:

- a. No more than two (2) Air Tanks, including any that aren't connected.
- b. No more than (1) Pneumatic Pump, including any that aren't connected.
- c. No additional parts that are not included in the VEX IQ Pneumatics Kit (e.g., unofficial tubing or fittings).

Note: There is no limit on the number of Pneumatic Cylinders or Pneumatic Control Units that may be used, provided that no other rules are violated. There are no restrictions on running the Pneumatic Pump prior to (or during) Matches.

The intent of <R16a> is to limit *Robots* to the air pressure stored in two Air Tanks, as well as the normal working air pressure contained in any Pneumatic Cylinders and tubing on the *Robot*. *Teams* may not use other elements for the purposes of storing or generating air pressure.

Using Pneumatic Cylinders or additional tubing solely for additional air storage is in *Violation* of the spirit of this rule. Similarly, using Pneumatic Cylinders and/or tubing without an actual pneumatic system (e.g., Air Tanks and/or a Pneumatic Pump) is also in *Violation* of the spirit of this rule.

Section 3

The Event

Description

The VEX IQ Robotics Competition encompasses both the *Teamwork Challenge* and the *Robot Skills Challenge*. This section determines how the *Teamwork Challenge* and *Robot Skills Challenge* are to be played at a given event. For information about the requirements for tournaments that qualify teams to championship events, [visit this article in the REC Library](#).

Awards may be given to top *Teams* in each format, as applicable. Awards may also be given for overall performance in the judged criteria. Please review the [Guide to Judging: Awards](#) article in the REC Library for more details.

Tournament Definitions

Event Partner – The volunteer VEX IQ Robotics Competition tournament coordinator who serves as an overall manager for the volunteers, venue, event materials, and all other event considerations. *Event Partners* serve as the official liaison between the REC Foundation, the event volunteers, and event attendees.

Finals Match – A *Teamwork Match* used to determine the *Teamwork Challenge* champions.

Head Referee – A certified impartial volunteer responsible for enforcing the rules in this manual as written. *Head Referees* are the only people who may discuss ruling interpretations or scoring questions with *Teams* at an event.

Match Stop Time – The time remaining (i.e., displayed on the timer or audience display) in a tiebreaker *Finals Match* when an *Alliance* ends the *Match* early by placing their controllers on the ground. The *Match Stop Time* is rounded down to the nearest even number. For example, if controllers are set down when the displayed time is 13 seconds, the *Match Stop Time* is recorded as 12 seconds. If an *Alliance* does not finish the *Match* early, they receive a default *Match Stop Time* of 0 seconds.

Practice Match – A non-scored *Match* used to provide time for *Teams* to get acquainted with the official playing *Field*.

Qualification Match – A *Teamwork Match* used to determine the event rankings.

Robot Skills Challenge – A portion of the VEX IQ Robotics Competition. The *Robot Skills Challenge* consists of *Driving Skills Matches* and *Autonomous Coding Skills Matches* as described in the General Definitions.

Scorekeeper Referee – An impartial volunteer responsible for tallying scores at the end of a *Match*. *Scorekeeper Referees* do not make ruling interpretations, and should redirect any *Team* questions regarding rules or scores to the *Head Referee*.

Teamwork Challenge – A portion of the VEX IQ Robotics Competition. The *Teamwork Challenge* consists of *Teamwork Matches*. The *Teamwork Challenge* includes *Qualification Matches* and *Finals Matches*, and may include *Practice Matches*.

Tournament Rules

<T1> The Head Referee has ultimate and final authority on all gameplay ruling decisions during the competition.

- a. *Scorekeeper Referees* score the *Match*, and may serve as observers or advisers for the *Head Referees*, but may not determine any rules or infractions directly.
- b. When issuing a *Disqualification* or warning to a *Team*, the *Head Referee* must provide the rule number of the specific rule that has been Violated, and record the *Violation* in the Match Anomaly Log.
- c. *Violations* of the REC Foundation Code of Conduct may involve additional escalation beyond the *Head Referee's* initial ruling, including (but not limited to) investigation by an REC Foundation representative. Rules <S1>, <G1>, and <G2> are the only rules for which this escalation may be required.
- d. *Event Partners* may not overrule a *Head Referee's* decision.
- e. Every *Qualification Match* & *Finals Match* must be watched by a *Head Referee*. *Head Referees* may only watch one *Match* at a time; if multiple *Matches* are happening simultaneously on separate fields, each field must have its own *Head Referee*.

Note from the VEX GDC: The rules contained in this Game Manual are written to be enforced by human *Head Referees*. Many rules have "black-and-white" criteria that can be easily checked. However, some rulings will rely on a judgment call from this human *Head Referee*. In these cases, *Head Referees* will make their calls based on what they and the *Scorekeeper Referees* saw, what guidance is provided by their official support materials (the Game Manual and the Q&A), and most crucially, the context of the *Match* in question.

The VEX IQ Robotics Competition does not have video replay, our *Fields* do not have absolute sensors to count scores, and most events do not have the resources for an extensive review conference between each *Match*.

When an ambiguous rule results in a controversial call, there is a natural instinct to wonder what the "right" ruling "should have been," or what the GDC "would have ruled." This is ultimately an irrelevant question; our answer is that when a rule specifies "*Head Referee's* discretion" (or similar), then the "right" call is the one made by the *Head Referee* in the moment. The VEX GDC designs games, and writes rules, with this expectation (constraint) in mind.

<T2> Head Referees must be qualified. VEX IQ *Head Referees* must have the following qualifications:

- a. Be at least 16 years of age.
- b. Be approved by the *Event Partner*.
- c. Be an REC Foundation Certified VIQRC *Head Referee* for the current season.

Note: Scorekeeper Referees must be at least 15 years of age, and must be approved by the Event Partner.

<T3> The Drivers are permitted to immediately appeal the Head Referee's ruling. If *Drivers* wish to dispute a score or ruling, they must stay in the *Driver Station* until the *Head Referee* talks with them. The *Head Referee* may choose to meet with the *Drivers* at another location and/or at a later time so that the *Head Referee* has time to reference materials or resources to help with the decision. Once the *Head Referee* announces that their decision has been made final, the issue is over and no more appeals may be made (See rule <T1>).

- a. *Head Referees* may not review any photo or video *Match* recordings when determining a score or ruling.
- b. *Head Referees* are the only individuals permitted to explain a rule, *Disqualification*, or warning to the *Teams*. *Teams* should never consult other field personnel, including *Scorekeeper Referees*, regarding a ruling clarification.

Communication and conflict resolution skills are an important life skill for *Students* to practice and learn. In VEX IQ Robotics Competitions, we expect *Students* to practice proper conflict resolution using the proper chain of command. *Violations* of this rule may be considered a *Violation* of <G1> and/or the Code of Conduct.

Some events may choose to utilize a "question box" or other designated location for discussions with *Head Referees*. Offering a "question box" is within the discretion of the *Event Partner* and/or *Head Referee*, and may act as an alternate option for asking *Drivers* to remain in the *Driver Station* (although all other aspects of this rule apply).

However, by using this alternate location, *Drivers* acknowledge that they are forfeiting the opportunity to use any contextual information involving the specific state of the *Field* at the end of the *Match*. For example, it is impossible to appeal whether a game element was *Scored* or not if the *Field* has already been reset. If this information is pertinent to the appeal, *Drivers* should still remain in the *Driver Station*, and relocate to the "question box" once the *Head Referee* has been made aware of the concern and/or any relevant context.

<T4> The Event Partner has ultimate authority regarding all non-gameplay decisions during an event. The Game Manual is intended to provide a set of rules for successfully playing VIQRC Full Volume; it is not intended to be an exhaustive compilation of guidelines for running a VEX IQ Robotics Competition event. Rules such as, but not limited to, the following examples are at the discretion of the *Event Partner* and should be treated with the same respect as the Game Manual:

- Venue access
- Pit spaces
- Health and safety
- *Team* registration and/or competition eligibility
- *Team* conduct away from competition fields

<T5> Be at your match on time. If no member of a *Team* is present in the *Driver Station* at the start of a *Match*, that *Team* is considered a “no show” and will receive zero (0) points. The other *Team* in the *Alliance* will still play and receive points for the *Match*.

<T6> Robots at the field must be ready to play. If a *Team* brings their *Robot* to the *Field*, it must be prepared to play (i.e., batteries charged, sized within the starting size constraint, etc.)

- a. *Robots* must be placed on the field promptly. Repeated failure to do so could result in a *Violation* of <G1> and/or removal of the *Robot* from the current *Match* at the *Head Referee’s* discretion.

<T7> Match Replays are allowed, but rare. *Match* replays (i.e., playing a *Match* over again from its start) are at the discretion of the *Event Partner* and *Head Referee*, and will only be issued in the most extreme circumstances. Some examples that may warrant a *Match* replay are as follows:

1. *Score Affecting* “Field fault” issues.
 - a. *Blocks* not starting in the correct positions.
 - b. *Field Elements* detaching or moving beyond normal tolerances, not a result of *Robot* interactions.
2. *Score Affecting* game rule issues.
 - a. A *Field* is reset before the score is determined.

<T8> Disqualifications. A *Team* that is issued a *Disqualification* in a *Qualification Match* receives zero (0) points for the *Match*. The other *Team* on their *Alliance* will still receive points for the *Match*.

- a. In *Finals Matches*, *Disqualifications* apply to the whole *Alliance*, not just one *Team*. An *Alliance* that receives a *Disqualification* in a *Finals Match* will receive zero (0) points.
- b. A *Team* that receives a *Disqualification* in a *Robot Skills Match* will receive a score of zero (0).

<T9> Timeouts. There are no timeouts in *Qualification Matches* or *Finals Matches*.

<T10> Be prepared for minor field variance. *Field Element* tolerances may vary from nominal by up to ± 1.0 ", unless otherwise specified. *Block* weights may vary from nominal by up to ± 2 grams. *Teams* are encouraged to design their *Robots* accordingly. Please make sure to check Appendix A for more specific nominal dimensions and tolerances.

<T11> Fields and Field Elements may be repaired at the Event Partner's discretion. All competition fields and other *Field Elements* at an event must be set up in accordance with the specifications in Appendix A and *I* or other applicable support materials. Minor aesthetic customizations or repairs are permitted, provided that they do not impact gameplay (see <T4>).

Examples of permissible modifications include, but are not limited to:

- Replacing a damaged or missing VEX IQ *Field* component with an identical part of any color
- Elevating the playing field off of the *Floor* (common heights are 10" to 24" [25.4cm to 61cm])
- Using off-the-shelf PVC to replace a damaged or missing *Supply Zone* pipe
- Removing the green and purple 0x2 pins that are used to help with field reset

<T12> Teamwork Matches. During *Teamwork Challenge Matches*, two (2) *Teams* form an *Alliance* that will play on the *Field*.

- a. *Qualification Match Alliances* are randomly selected.
- b. *Finals Match Alliances* are assigned as follows:
 - i. The first and second ranked *Teams* form an *Alliance*.
 - ii. The third and fourth ranked *Teams* form an *Alliance*.
 - iii. And so on, until all *Teams* participating in *Finals Matches* have formed an *Alliance*.

<T13> Ending a Match early. If an *Alliance* wants to end a *Qualification Match* or a *Finals Match* early, both *Teams* must signal the referee by ceasing all *Robot* motion and placing their controllers on the ground. The referee will then signal to the *Teams* that the *Match* is over and will begin to tally the score. If the *Match* is a tiebreaker *Finals Match*, then the *Match Stop Time* will also be recorded.

<T14> Practice Matches may be played at some events, but are not required. If *Practice Matches* are run, every effort will be made to equalize practice time for all *Teams*.

<T15> Qualification Matches will occur according to the official match schedule. This schedule will indicate *Alliance* partners, *Qualification Match* times, and, if the event has multiple *Fields*, which *Field* each *Qualification Match* will be played on.

Note: The official Match schedule is subject to changes at the Event Partner’s discretion.

<T16> Each Team will be scheduled Qualification Matches as follows.

- a. When in a tournament, the tournament must have a minimum of six (6) *Qualification Matches* per team at local qualifying events and eight (8) for a Championship event.
- b. When in a league, there must be at least three (3) league ranking sessions, with at least one (1) week between sessions. Each session must have a minimum of two (2) *Qualification Matches* per *Team*. The suggested number of *Qualification Matches* per *Team* for a standard league ranking session is four (4). *Event Partners* may choose to have *Qualification Matches* as part of their league finals session.

<T17> Teams are ranked by their average Qualification Match scores.

- a. When in a tournament, every *Team* will be ranked based on the same number of *Qualification Matches*.
 - i. For tournaments that have more than 1 division, *Teams* will be ranked among all *Teams* in their specific division. Each division will have its own set of *Finals Matches*. The winners of each division will then have an overall event Finals. Any multi-division event must be approved by the REC Foundation EEM/RSM prior to the event, and divisions must be assigned in sequential order by *Team* number.
- b. When in a league, every *Team* will be ranked based on the number of *Matches* played. *Teams* that participate in less than 60% of the total *Matches* available will be ranked below *Teams* that participate in at least 60% of the total *Matches* available (e.g., if the league offers 3 ranking sessions with 4 *Qualification Matches* per *Team*, *Teams* that participate in 8 or more *Matches* will be ranked higher than *Teams* who participate in 7 or fewer *Matches*). Being a no-show to a *Match* that a *Team* is scheduled in still constitutes participation for these calculations.
- c. A certain number of a *Team’s* lowest *Qualification Match* scores will be excluded from the rankings based on the quantity of *Qualification Matches* each *Team* plays. Excluded scores do not affect participation for leagues.

Number of Qualification Matches per Team	Number of excluded Match scores
Between four (4) and seven (7)	1
Between eight (8) and eleven (11)	2
Between twelve (12) and fifteen (15)	3
Sixteen (16) or more	4

- d. In some cases, a *Team* will be asked to play an additional *Qualification Match*. The extra *Match* will be identified on the *Match Schedule* with an asterisk and will not impact the *Team’s* ranking (or participation for leagues). *Teams* are reminded that <G1>s is always in effect and *Teams* are expected to behave as if the additional *Qualification Match* counted.

- e. Ties in *Team* ranking are broken by:
 - i. Removing the *Team's* lowest score and comparing the new average score.
 - ii. Removing the *Team's* next lowest score and comparing the new average score (on through all scores).
 - iii. If the *Teams* are still tied, the *Teams* will be sorted by random electronic draw.

<T18> Teams playing in Finals Matches. The number of *Finals Matches*, and therefore the number of *Teams* who will participate in *Finals Matches*, is determined by the *Event Partner*. Events that qualify teams directly to VEX Worlds must have a minimum of five (5) *Finals Matches* if there are ten (10) or more *Teams* in attendance.

<T19> Finals Match Schedule. *Finals Matches* are played sequentially, starting with the lowest-ranked *Alliance*. Each *Alliance* will participate in one (1) *Finals Match*. The *Alliance* with the highest *Finals Match* score is the *Teamwork Challenge* champion.

- a. *Alliances* are ranked by their *Finals Match* score. The highest-scoring *Alliance* is in first place, the second-highest-scoring *Alliance* is in second place, etc.
- b. Ties for first place will result in a series of tiebreaker *Finals Matches*, starting with the lower-seeded *Alliance*. The *Alliance* with the highest tiebreaker *Finals Match* score will be declared the *Teamwork Challenge* champion.
 - i. If the tiebreaker *Finals Match* scores are tied, the *Alliance* with the higher *Match Stop Time* will be declared the winner.
 - ii. If the *Match Stop Time* is also tied, a second series of tiebreaker *Finals Matches* will be played. If this second series of tiebreaker *Finals Match* is also tied, then the higher-seeded *Alliance* will be declared the winner.
 - iii. If there is a tie for a place other than first, the higher-seeded *Alliance* will receive the higher rank.

Example 1: *Alliance 6* and *Alliance 3* are tied for first place. During the tiebreaker *Finals Match*, *Alliance 6* scores 13 points and has a *Match Stop Time* of 12 seconds. *Alliance 3* scores 13 points and has a *Match Stop Time* of 10 seconds. *Alliance 6* is the *Teamwork Challenge* winner.

Example 2: *Alliance 4* and *Alliance 5* are tied for third place. *Alliance 4* is the third place winner and *Alliance 5* is the fourth place winner. In this way, the lower ranked *Alliance* must "overcome" the higher ranked *Alliance* in order to become the *Teamwork Challenge* champion.

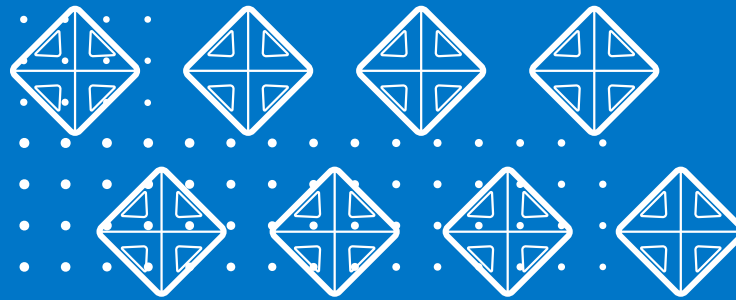

vEX IQ
COMPETITION
FULL VOLUME

2023 - 2024

Appendix A - Field Overview and Specifications

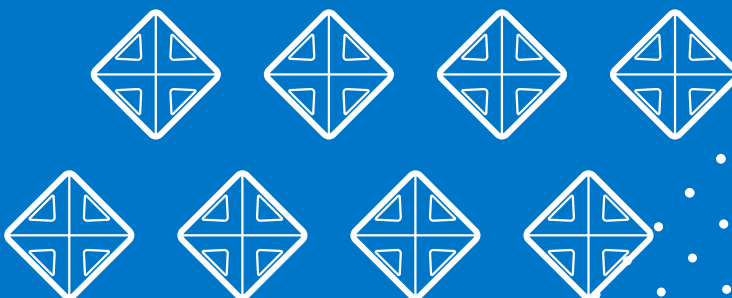

Appendix A - Field Overview

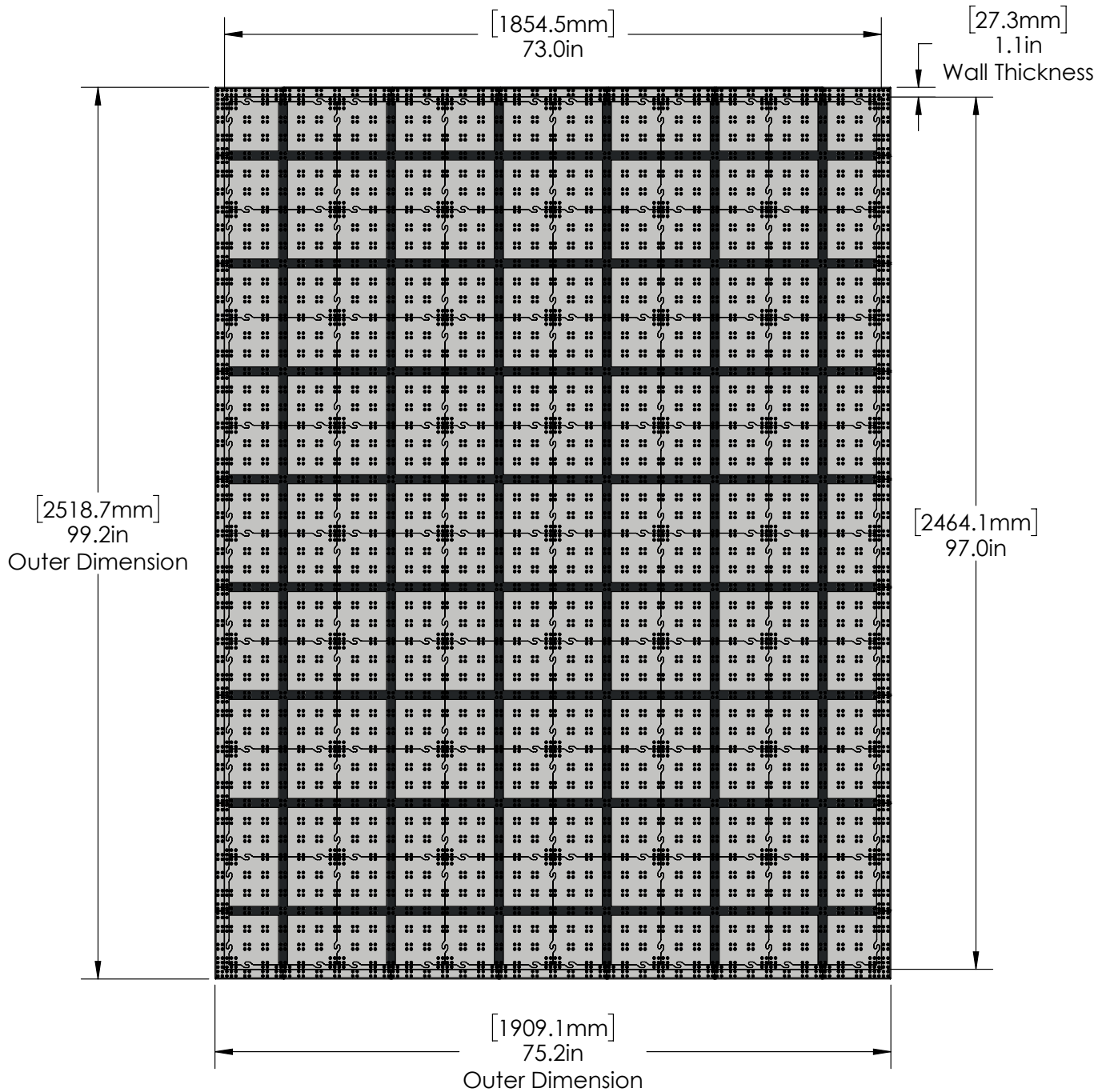

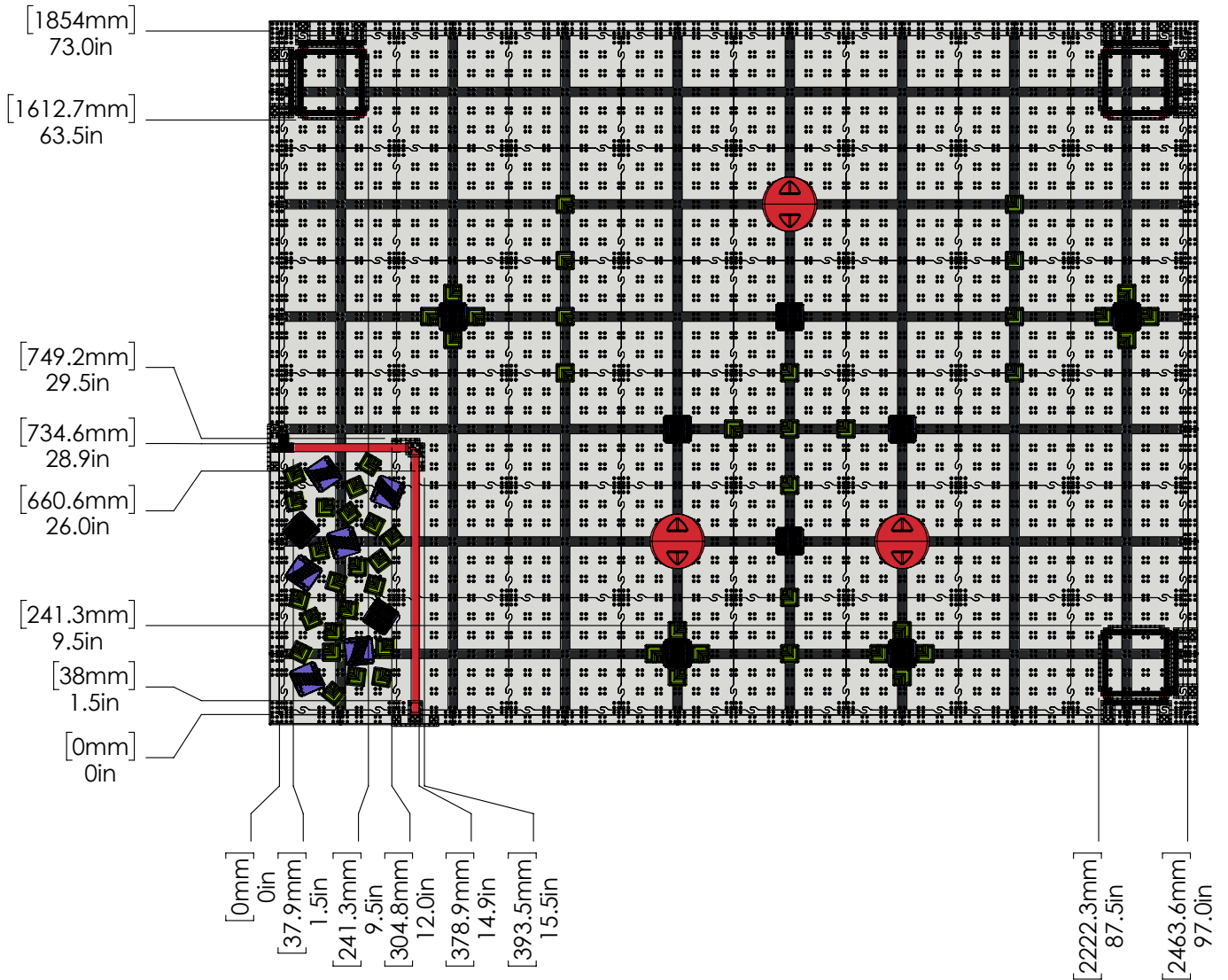

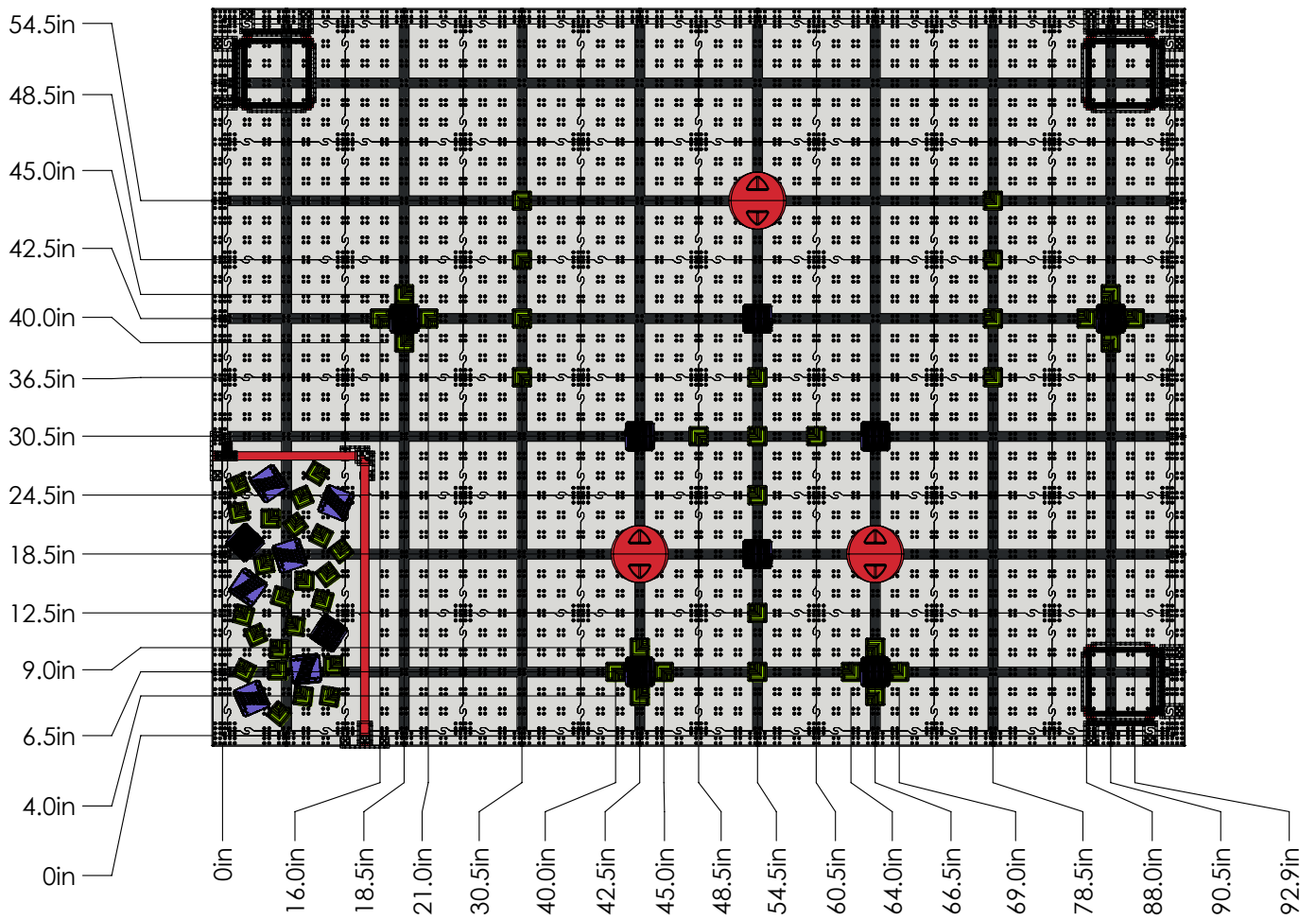

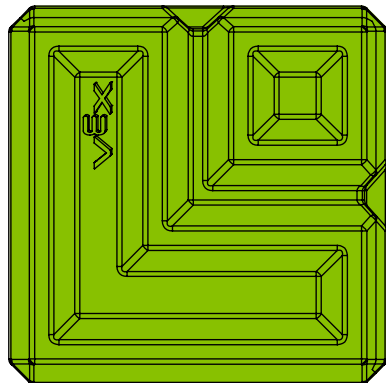
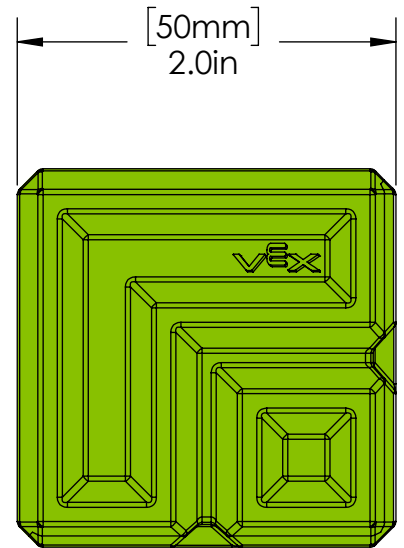
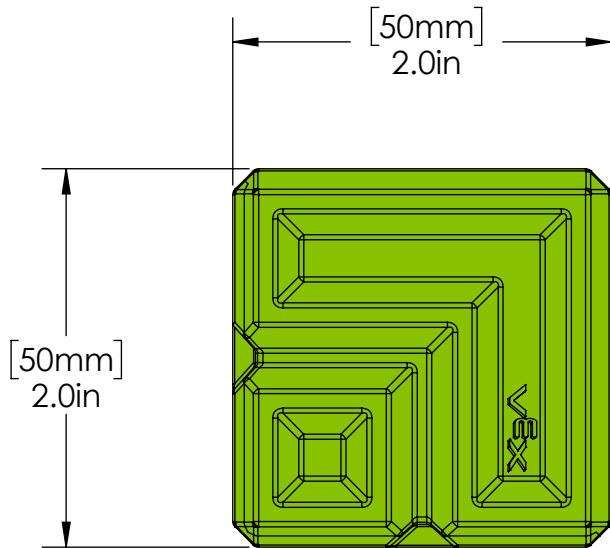

Approximate Weight:
30g

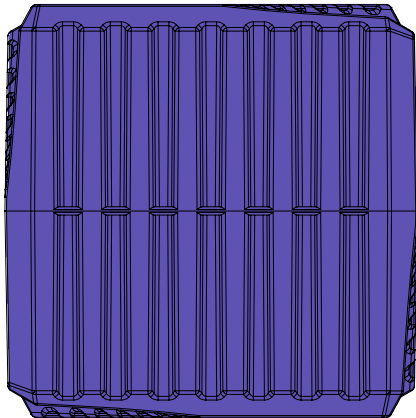
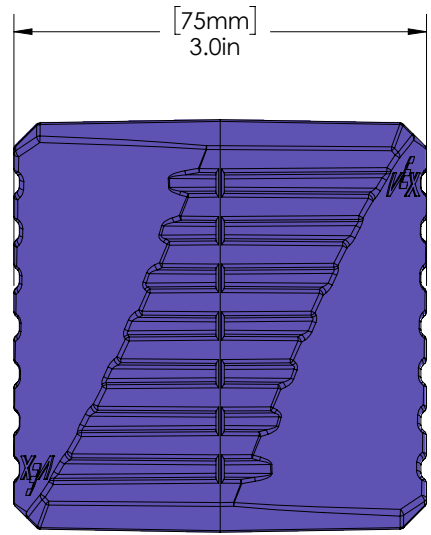
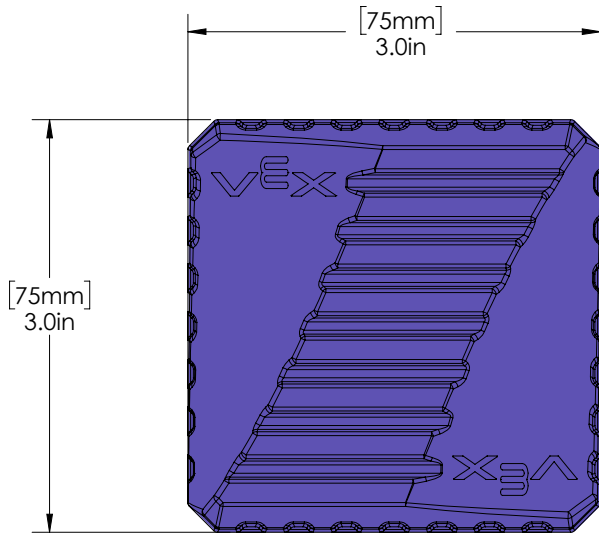

Approximate Weight:
45g

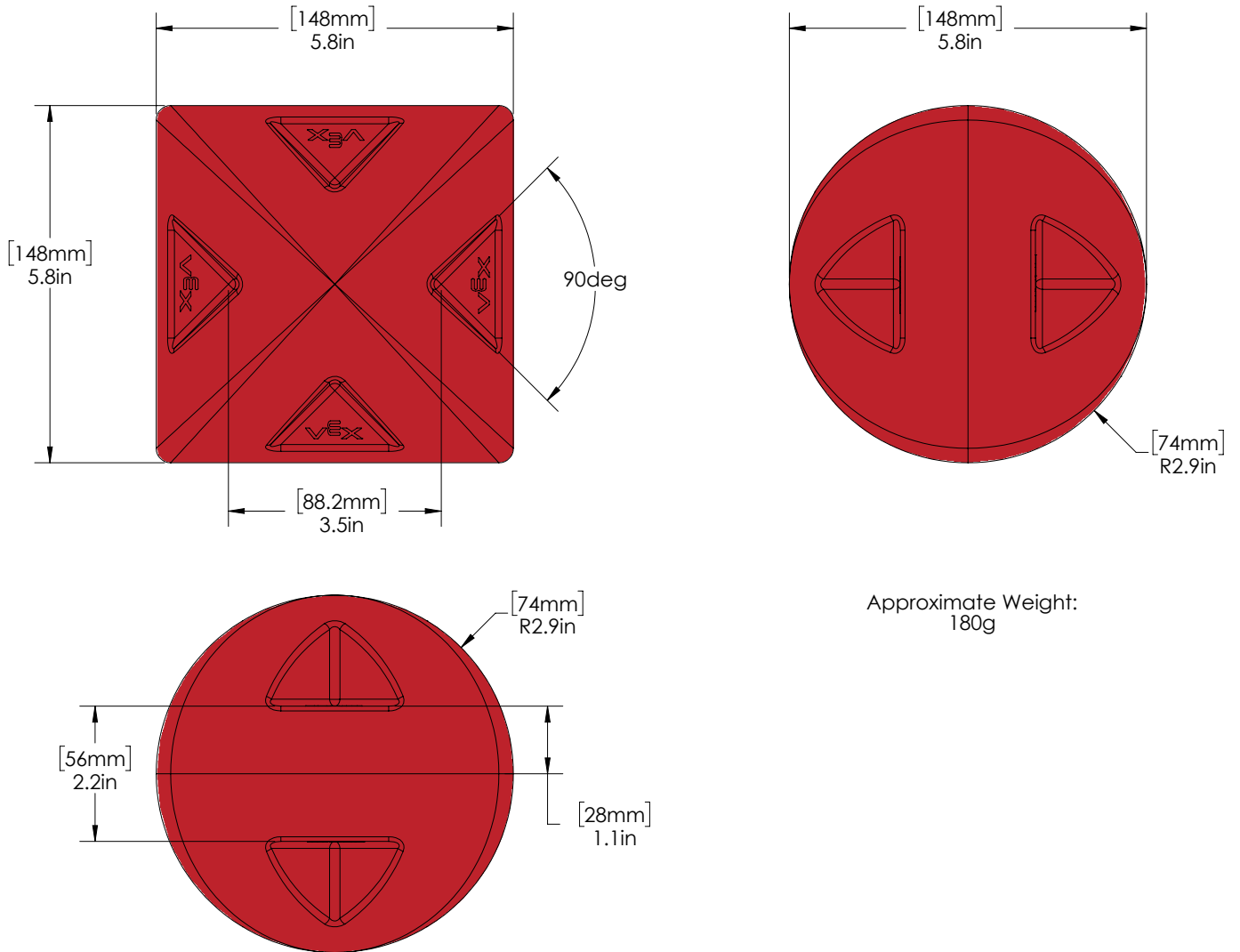

Approximate Weight:
180g

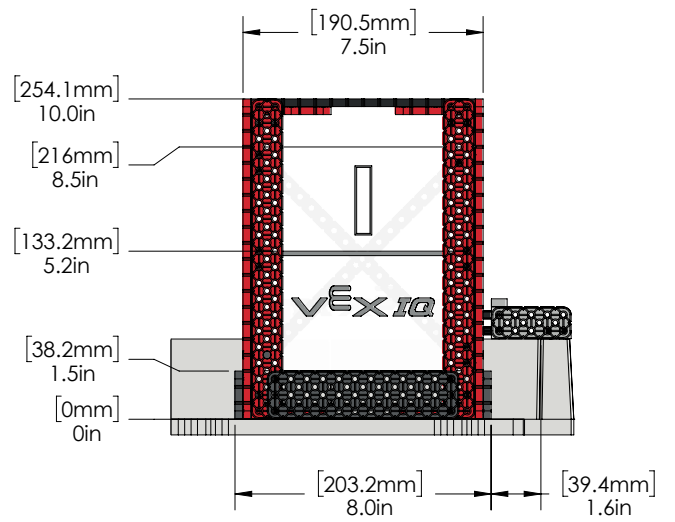
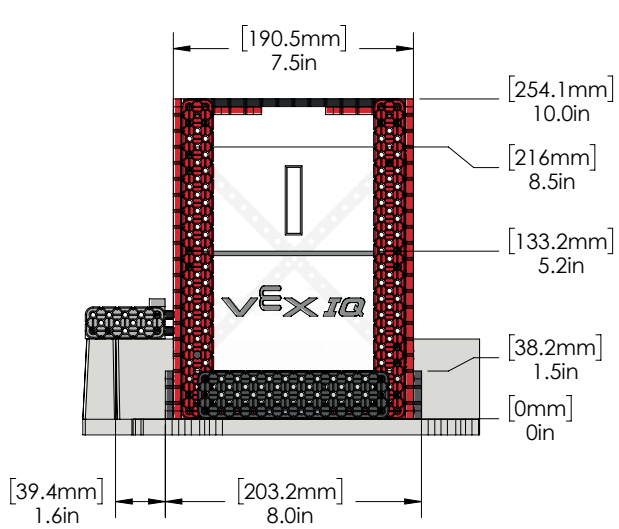
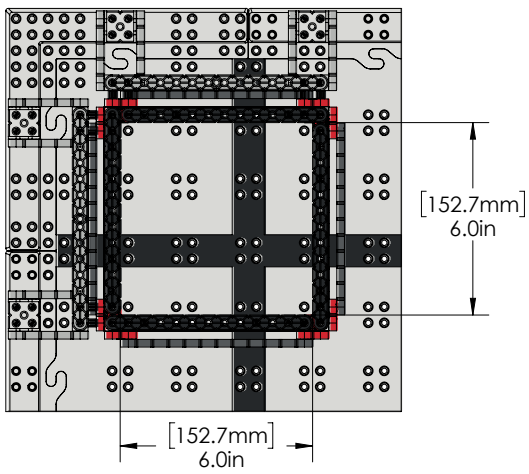

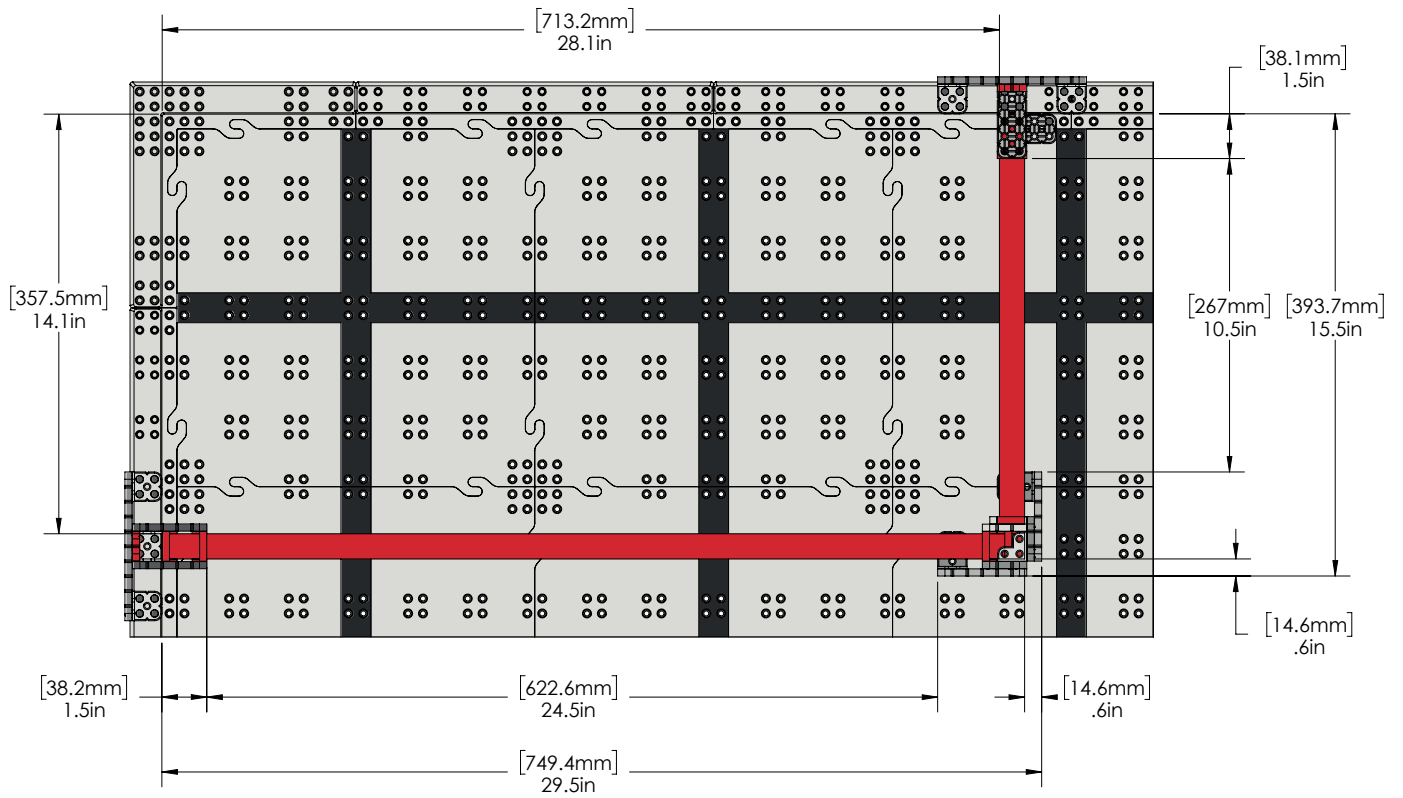

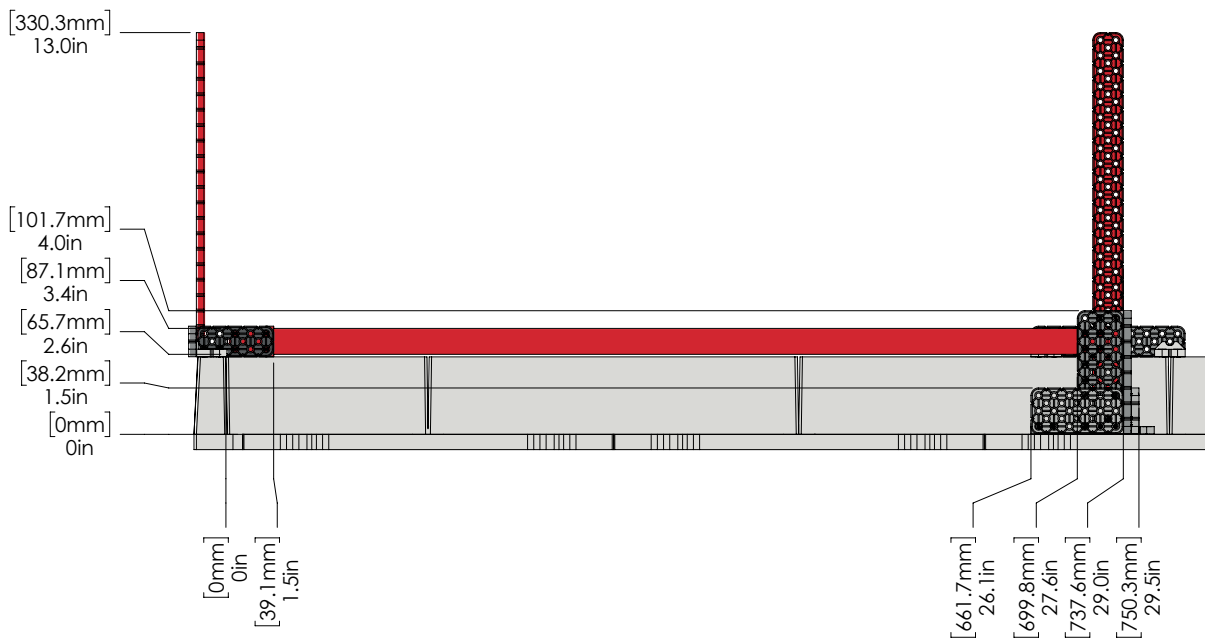

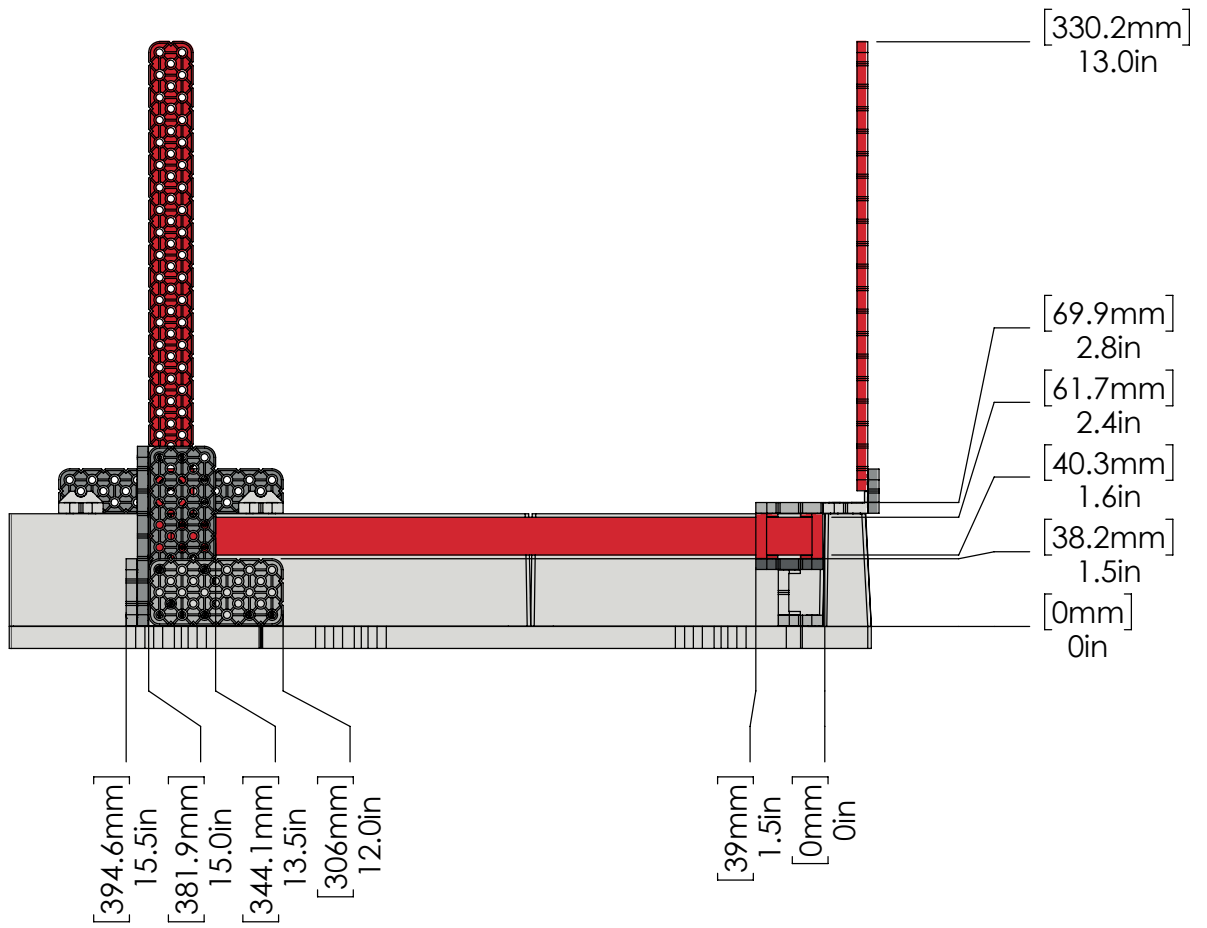

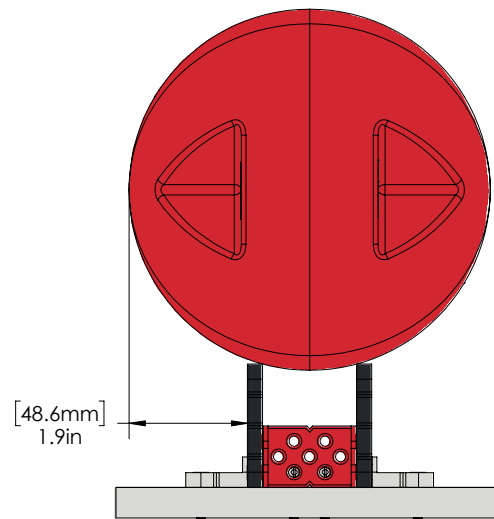
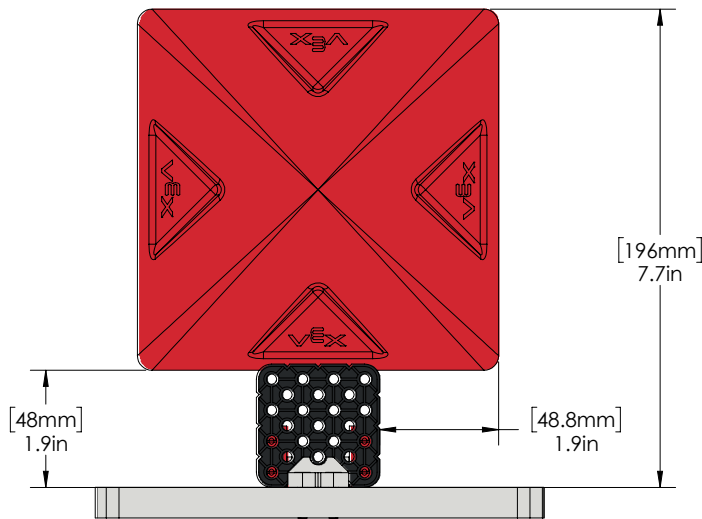
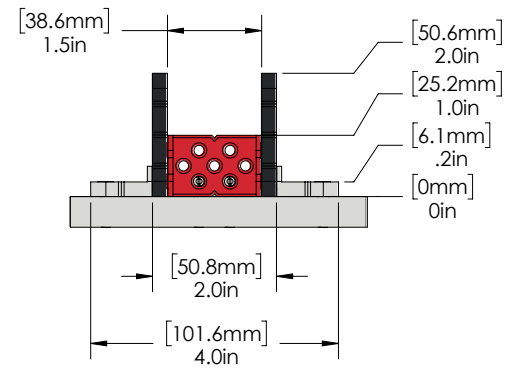
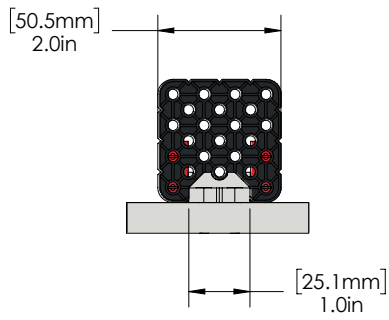

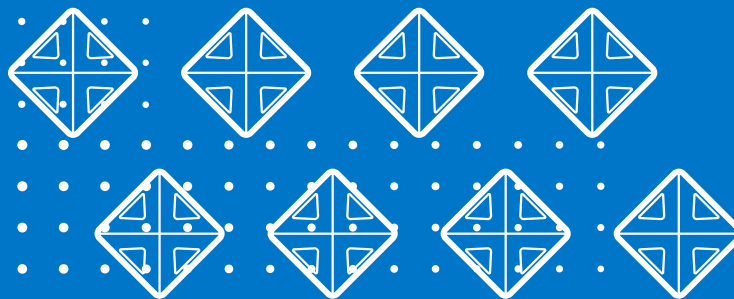

vEX IQ
COMPETITION
FULL VOLUME

2023 - 2024
Appendix B - Robot Skills Challenge

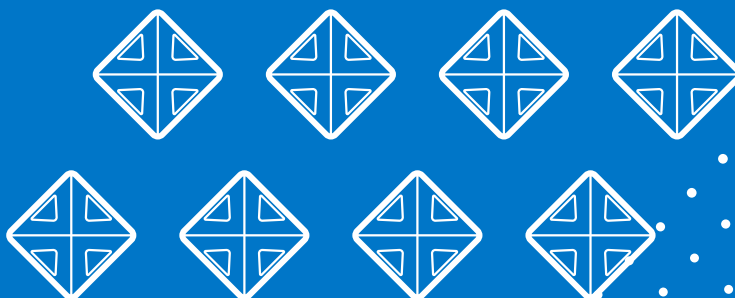

Appendix B - Robot Skills

Overview

In this challenge, *Teams* will compete in sixty-second (1:00) *Matches* in an effort to score as many points as possible. These *Matches* consist of *Driving Skills Matches*, which are entirely driver controlled, and *Autonomous Coding Skills Matches*, which are autonomous with limited human interaction. *Teams* will be ranked based on their combined score in the two types of *Robot Skills Matches*.

Robot Skills Challenge at a Standard Qualifying Tournament

- The Robot Skills Challenge is an optional event for all *Teams*. *Teams* who do not compete will not be penalized in the *Teamwork Challenge* portion of the tournament. However, participation in the Robot Skills Challenge may impact eligibility for judged awards at the event.
- *Teams* may play *Robot Skills Matches* on a "first come, first served" basis, or by a pre-scheduled method determined by the *Event Partner*.
- *Teams* will be given the opportunity to play exactly three (3) *Autonomous Coding Skills Matches* and three (3) *Driving Skills Matches*. *Teams* should be aware of when the Robot Skills fields are open so that they do not miss their opportunity, (e.g., if a *Team* waits until five minutes before the Robot Skills fields close, then they have not used the opportunity given to them and will not be able to compete in all six matches).
- Further details regarding Skills-Only Event logistics can be found in the REC Foundation Qualification Criteria document.

Robot Skills Challenge Definitions

All definitions from "The Game" section of the manual apply to the Robot Skills Challenge, unless otherwise specified.

Driving Skills Match – A *Driving Skills Match* consists of a sixty-second (1:00) *Driver Controlled Period*. There is no *Autonomous Period*. *Teams* can elect to end a *Driving Skills Match* early if they wish to record a *Skills Stop Time*.

Autonomous Coding Skills Match – An *Autonomous Coding Skills Match* consists of a sixty-second (1:00) *Autonomous Period*. There is no *Driver Controlled Period*. *Teams* can elect to end an *Autonomous Coding Skills Match* early if they wish to record a *Skills Stop Time*.

Robot Skills Match – A *Driving Skills Match* or *Autonomous Coding Skills Match*.

Skills Stop Time – The time remaining in a *Robot Skills Match* when a *Team* ends the *Match* early.

- If a *Team* does not end the *Match* early, they receive a default *Skills Stop Time* of 0.
- The moment when the *Match* ends early is defined as the moment when the *Robot* and *Blocks* have come to a rest and the *Driver* provides the agreed upon visual and audio signal to the Referee. See <RSC7> for more details.

- c. If a Tournament Manager display is being used for field control, then the *Skills Stop Time* is the time shown on the display when the *Match* is ended early (i.e., in 1-second increments).
- d. If a manual timer is being used that counts down to 0 with greater accuracy than 1-second increments, then the time shown on the timer should be rounded up to the nearest second. For example, if the *Robot* is disabled and the timer shows 25.2 seconds, then the *Skills Stop Time* should be recorded as 26.

Robot Skills Challenge Rules

<RSC1> Standard rules apply in most cases. All rules and scoring from previous sections apply to the *Robot Skills Matches*, unless otherwise specified.

- a. There is no *Double Parked* bonus for *Robot Skills Matches*.

<RSC2> Skills Scoring and Ranking at events. For each *Robot Skills Match*, *Teams* are awarded a score based on the standard rules and scoring rules. *Teams* will be ranked based on the following scores and tiebreakers:

1. Sum of highest *Autonomous Coding Skills Match* score and highest *Driving Skills Match* Score.
2. Highest *Autonomous Coding Skills Match* score.
3. Second-highest *Autonomous Coding Skills Match* score.
4. Second-highest *Driving Skills Match* score.
5. Highest sum of *Skills Stop Times* from a *Team's* highest *Autonomous Coding Skills Match* and highest *Driving Skills Match* (i.e., the *Matches* in point 1).
6. Highest *Skills Stop Time* from a *Team's* highest *Autonomous Coding Skills Match* (i.e., the *Match* in point 2).
7. Third-highest *Autonomous Coding Skills Match* score
8. Third-highest *Driving Skills Match* score.
9. If the tie cannot be broken after all above criteria (i.e., both *Teams* have the exact same scores and *Skills Stop Times* for each *Autonomous Coding Skills Match* and *Driving Skills Match*), then the following ordered criteria will be used to determine which team had the "best" *Autonomous Coding Skills Match*:
 - a. Points for *Blocks Scored in Goals*
 - b. Points for *Height Bonus*
 - c. Points for *Uniform Goals*
10. If the tie still cannot be broken, the same process in the step above will be applied to the *Teams'* highest *Driving Skills Matches*.
11. If the tie still isn't broken, the *Event Partner* may choose to allow *Teams* to have one more deciding *Match*, or both *Teams* may be declared the winner.

<RSC3> Skills Rankings Globally. Teams are ranked based on their *Robot Skills Match* scores globally using the following tiebreakers.

1. Highest Robot Skills score (combined *Autonomous Coding Skills Match* and *Driving Skills Match* Score from a single event).
2. Highest *Autonomous Coding Skills Match* score (from any event).
3. Highest sum of *Skills Stop Times* from the *Robot Skills Matches* used for point 1.
4. Highest *Skills Stop Time* from the *Autonomous Coding Skills Match* used for point 2.
5. Highest *Driving Skills Match* score (from any event).
6. Highest *Skills Stop Time* from the *Driving Skills Match* score used in point 5.
7. Earliest posting of the highest *Autonomous Coding Skills Match* score.
 - a. The first *Team* to post a score ranks ahead of other *Teams* that post the same score at a later time, all else being equal.
8. Earliest posting of the highest *Driving Skills Match* score.
 - a. The first *Team* to post a score ranks ahead of other *Teams* that post the same score at a later time, all else being equal.

<RSC4> Skills Match Schedule. Teams play *Robot Skills Matches* on a first-come, first-served basis. Each *Team* will get the opportunity to play exactly three (3) *Driving Skills Matches* and three (3) *Autonomous Coding Skills Matches*.

Teams should review the event agenda and their *Match* schedule to determine when the best possible time is to complete their *Robot Skills Matches*. If the *Robot Skills Challenge* area closes before a *Team* has completed all six (6) *Robot Skills Matches*, but it is determined that there was adequate time given, then the *Team* will automatically forfeit those unused *Matches*.

<RSC5> Handling Robots during an Autonomous Coding Skills Match. A *Team* may handle their *Robot* as many times as desired during an *Autonomous Coding Skills Match*.

- a. Upon handling the *Robot*, it must be immediately brought back to any legal Starting Position.
 - i. *Drivers* may reset or adjust the *Robot* as desired from this position, including pressing buttons on the *Robot Brain* or activating sensors.
- b. Any *Blocks* being controlled by the *Robot* while being handled must be removed from the *Field*, and can be returned to the *Supply Zone* by a referee or *Driver*. "Controlled" requires that the *Robot* was manipulating the *Block* and not simply touching it (e.g., if the *Block* moves with the *Robot* either vertically or while turning, the *Robot* is controlling the *Block*).
- c. Any *Blocks* within the chosen Starting Position for a reset must be removed from the *Field* and can be returned to the *Supply Zone* by a referee or *Driver*.

- d. During an *Autonomous Coding Skills Match*, *Drivers* may move freely around the *Field*, and are not restricted to the *Driver Station* when not handling their *Robot*.
 - i. The rest of <G8>, which states that *Drivers* are not allowed to use any communication devices during their *Match*, still applies.
 - ii. An intent of this exception is to permit *Drivers* who wish to "stage" *Robot* handling during an *Autonomous Coding Skills Match* to do so without excessive running back and forth to the *Driver Station*.

Note: This rule only applies to Autonomous Coding Skills Matches. Driving Skills Matches are still governed by <G9> & <G10>, especially for strategic violations.

Note 2: Any Blocks which remain outside of the Field at the end of a Match will be considered "in" the Supply Zone (i.e., the Supply Zone will not be eligible to be Cleared).

<RSC6> Starting an Autonomous Coding Skills Match. *Drivers* must start a *Robot's Autonomous Coding Skills Match* routine by pressing a button on the *Robot Brain* or manually activating a sensor. Because there is no VEX IQ Controller hand-off, only one (1) *Driver* is required for an *Autonomous Coding Skills Match* (though *Teams* may still have two (2) if desired).

- a. Pre-match sensor calibration is considered part of the standard pre-*Match* setup time (i.e., the time when the *Team* would typically be turning on the *Robot*, moving any mechanisms to their desired legal start position, etc.).
- b. Pressing a button on the VEX IQ Controller to begin the routine is not permitted. To avoid any confusion, *Teams* are advised not to bring controllers to *Autonomous Coding Skills Match*.

In accordance with <T6>, *Teams* should be mindful of event schedules and set their *Robot* up as promptly as possible. The definition of "prompt" is at the discretion of the *Event Partner* and *Head Referee*, and could depend on things like how much time is left for the Skills Challenge field(s) to be open, how many *Teams* are waiting in line, etc. As a general guideline, three seconds to calibrate a Gyro Sensor would be acceptable, but three minutes to debug a program would not.

<RSC7> Skills Stop Time. If a *Team* wishes to end their *Robot Skills Match* early, they may elect to record a *Skills Stop Time*. This is used as a tiebreaker for *Robot Skills Challenge* rankings. A *Skills Stop Time* does not affect a *Team's* score for a given *Robot Skills Match*. *Drivers* and field staff must agree prior to the *Match* on the signal that will be used to end the *Match* early.

- a. As noted in the definition of *Skills Stop Time*, the moment when the *Match* ends early is defined as the moment when the *Robot* and *Blocks* have come to a rest and the *Driver* provides the agreed upon visual and audio signal to the *Scorekeeper Referee*.
- b. *Teams* who intend to attempt a *Skills Stop Time* must "opt-in" by verbally confirming with the *Scorekeeper Referee* prior to the *Robot Skills Match*. If no notification is given prior to the start of the *Match*, then the *Team* forfeits their option to record a *Skills Stop Time* for that *Match*.

- c. This conversation should include informing the *Scorekeeper Referee* which *Driver* will signal the stop. The *Match* may only be ended early by a *Driver* for that *Match*.
- d. The agreed-upon signal to stop the match must be both verbal and visual, such as *Drivers* crossing their arms in an "X" or placing their VEX IQ Controller on the ground.
- e. It is recommended that the *Driver* also provides a verbal notice that they are approaching their *Skills Stop Time*, such as counting out "3-2-1-stop."
- f. If a *Team* runs multiple *Robot Skills Matches* in a row, they must reconfirm their *Skills Stop Time* choice with the *Scorekeeper Referee* prior to each *Match*.
- g. Any questions regarding a *Skills Stop Time* should be reviewed and settled immediately following the *Match*. <T1> and <T3> apply to *Robot Skills Matches*.

Robot Skills at League Events

At league events in which *Teams* may submit *Robot Skills Challenge* scores across multiple days / sessions, the Robot Skills scores (combined highest *Autonomous Coding Skills Match* and *Driving Skills Match* scores) used for rankings will be calculated from *Matches* within the same session.

For example, consider the following scores for a hypothetical *Team* across two league event sessions:

	Autonomous Coding Skills Match	Driving Skills Match	Robot Skills Score
Session 1	100	100	200
Session 2	150	40	190

This *Team* would have a Robot Skills score of 200 for this event, and their scores from Session 1 would be used for the Event and Global tiebreakers listed in the above two sections.